

A Self-Powered Generator

A free-energy developer who prefers to remain anonymous and who lives in South Africa, has very kindly shared the details of his compact self-powered generator so that you can build one if you choose to do so. Using a small inverter, the output of the prototype is 40 watts at mains voltage and frequency and the generator is a small table-top unit. The generator can be used in different configurations, and initially, here is one version which charges three 12-volt batteries as well as producing its continuous output. South Africa is a place where it is difficult to get many quite ordinary electronic components and so the developer recovers batteries and components from discarded equipment. The batteries are like this one:

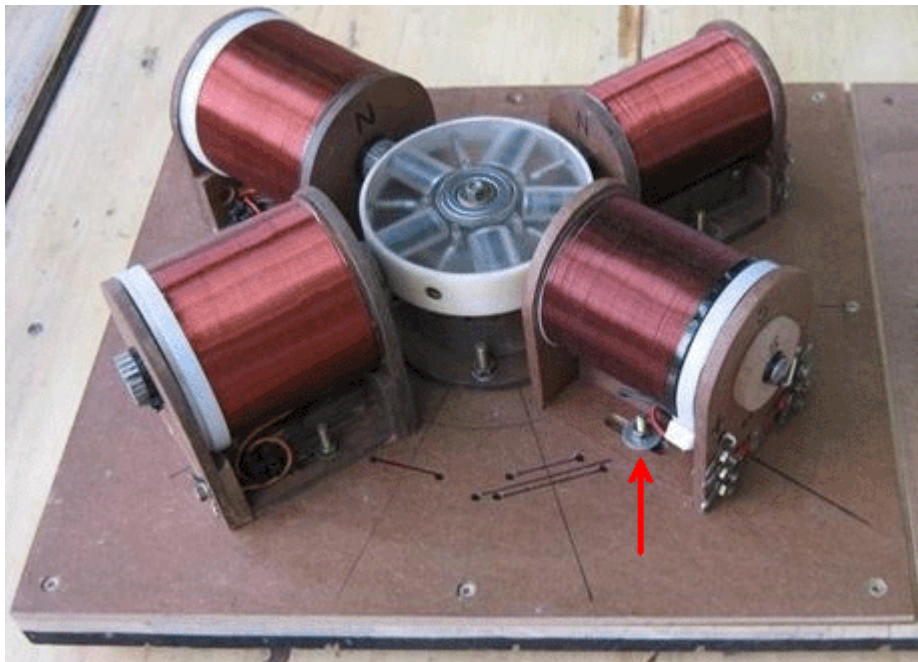

This is a self-powered generator which has a continuous electrical output, day and night – a bit like a solar panel which works at night as well as during the day. An early version of the generator had four coils and a rotor which has five magnets in it:



The red arrow draws your attention to the fact that the gap between the rotor and the coils can be adjusted by loosening the mounting bolts and sliding the coil along the mounting slots. The gap can be anything from 1mm to 10 mm.

The rotor needs to be very accurate and was made on a lathe. It is cut from a piece of one inch thick, very clear acrylic plastic and it has five sets of nine ferrous magnets installed in holes drilled into the very clear (solid) plastic. A white retaining ring cut from a pipe, is used to ensure that the magnets remain in place at all times:



Very soon, the four coils were increased to five with the additional coil having three separate windings. Even if you are not familiar with electronics circuit diagrams, please try to follow along as we run through the circuit diagram and explain how the generator works. This is the basic circuit diagram:

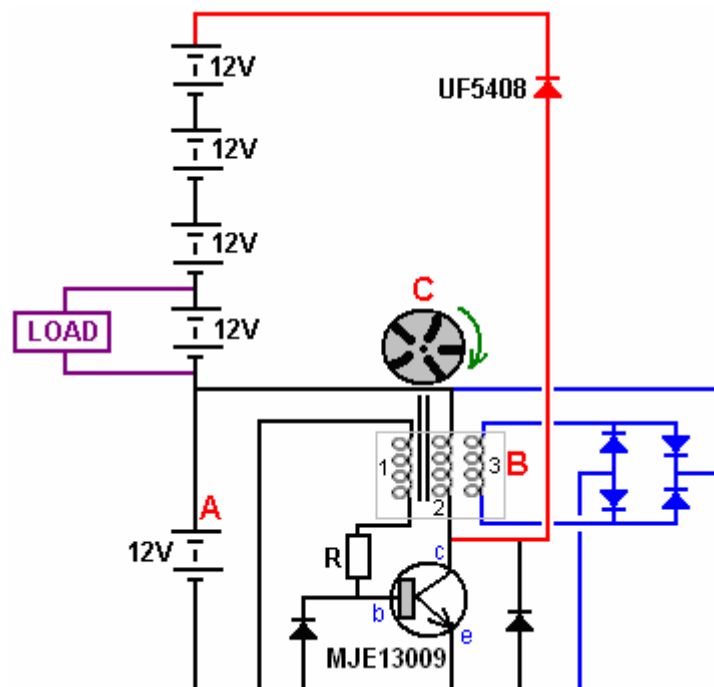

The battery marked "A" powers the circuit. A rotor "C", containing five magnets is moved so that one of the magnets passes near the coils. The coils set "B" has three separate windings on a single core and the magnet moving past those three coils generates a small current in them. The current in coil number "1" flows through the resistor "R" and into the base of the transistor, causing it to switch on. The power flowing through the transistor coil "2" causes it to become a magnet and that pushes the rotor disc "C" on its way, keeping the rotor spinning. It also induces a current in the winding "3" and that current is rectified by the blue diodes and passed back to charge battery "A", replacing most of the current drawn from that battery.

When the magnet in rotor “C” passes away from the coils, the transistor switches off, moving its collector voltage very quickly up to the +12 Volt line, starving coil “2” of current. Because of the way that coils are, the coil drags the collector voltage on up and it would reach 200 volts or more if it were not connected through the red diode to all five batteries which are connected in one long chain. The batteries will have a combined voltage of just over 60 volts (which is why a powerful, fast-switching, high-voltage MJE13009 transistor is being used). As the collector voltage passes the voltage of the battery chain the red diode starts conducting, passing the available energy in the coil into the battery chain. That current pulse passes through all five batteries, charging all of them. Loosely speaking, that is the generator design.

In the prototype, the load for long-term testing was a twelve volt 150-watt inverter powering a 40-watt mains light bulb:

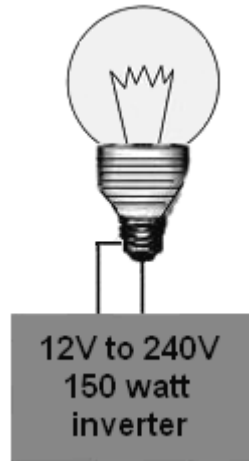

The basic design shown above was then modified by the addition of two additional pick-up coils:

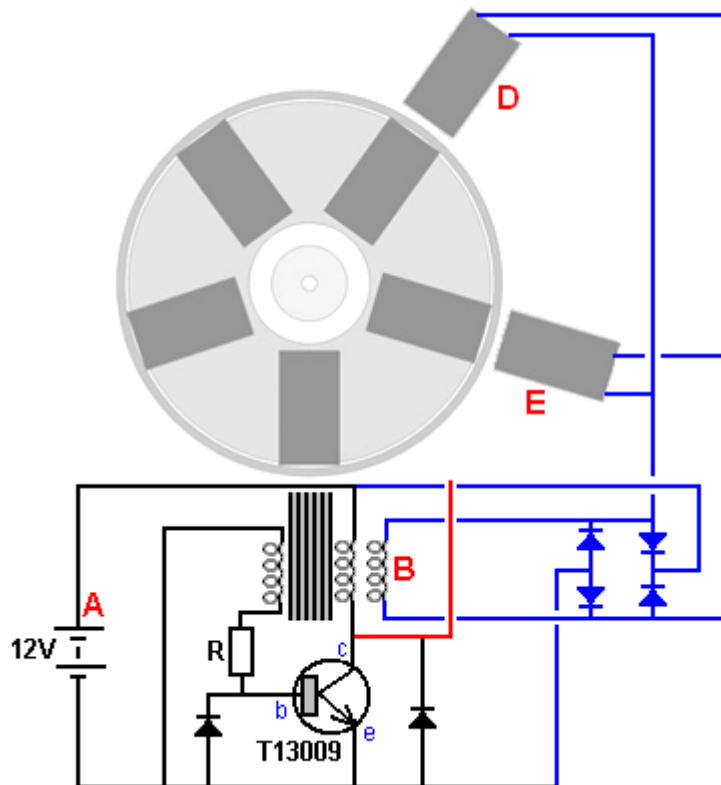

Coils “B”, “D” and “E” are all triggered at the same time by three different magnets. The electrical energy produced in all three coils is passed to the four blue diodes to produce a DC power supply which is used to charge battery “A” which powers the circuit. That additional input to the drive battery caused by the addition of two more drive coils to the stator, makes the system operate securely as self-powered, maintaining the voltage of battery “A” indefinitely.

The only moving part of this system is the rotor which is 110 mm in diameter and is a 25 mm thick acrylic disc mounted on a bearing taken from an old computer hard disc drive. The arrangement looks like this:

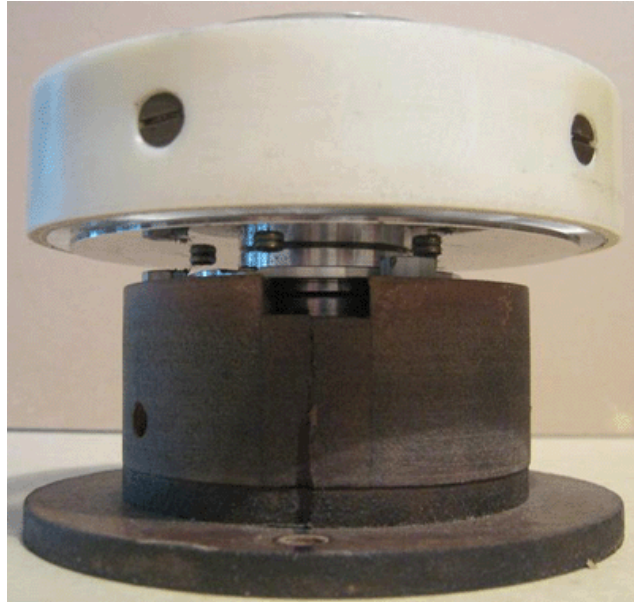

In the pictures, the disc looks to be hollow but in actual fact it is solid, very clear plastic. The disc has been drilled at five evenly spaced points around the circumference, that is, at 72 degree intervals. The five main holes drilled in the disc are to take the magnets which are sets of nine circular ferrite magnets, each 20 mm in diameter and 3 mm thick, making each stack of magnets 27 mm long and 20 mm in diameter. The magnet stacks are positioned so that their North poles face outwards. When the magnets have been installed, the rotor is placed inside a strip of plastic pipe which prevents the magnets escaping when the disc is spun rapidly. The plastic pipe is secured to the rotor using five bolts with countersunk heads.

The spools of the coils are 80 mm long and the ends are 72 mm in diameter. The centre shaft of each coil is made of a length of plastic pipe with a 20 mm outer diameter and an inner diameter of 16 mm. giving a wall thickness of 2 mm. After being wound, that inner diameter is filled with a series of welding rods with their welding coating removed, and which are then encased in polyester resin although a solid bar of soft iron is a good alternative:

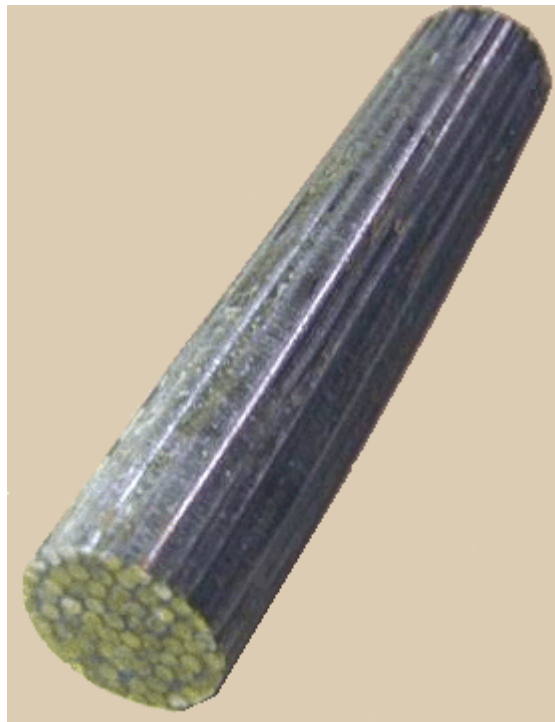

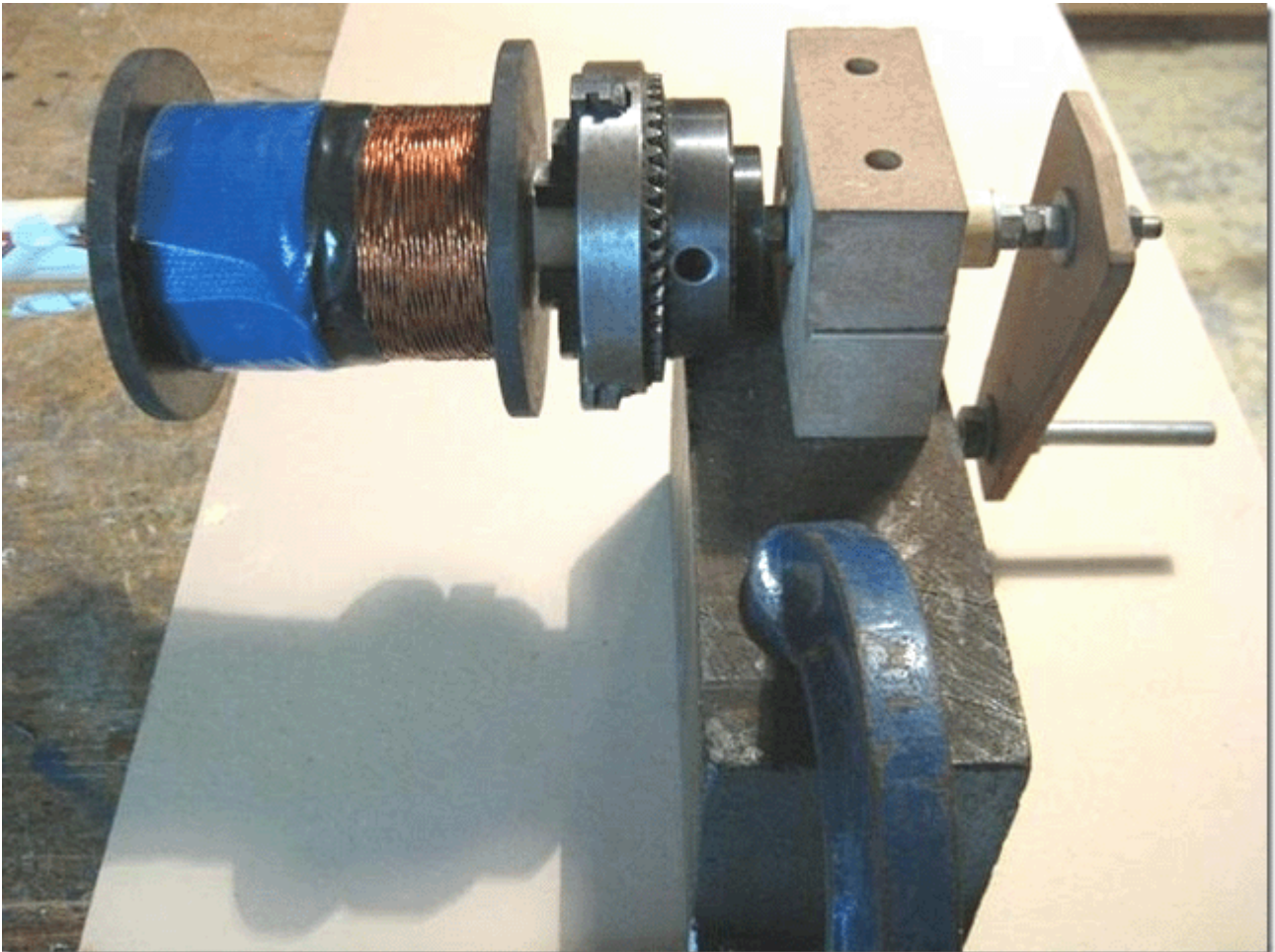

The three strands of wire which form coils "1", "2" and "3" are 0.7 mm diameter wire and they are twisted together before being wound into the coil "B". This produces a much thicker composite wire group which is easy to wind on to the spool accurately. The winder shown above uses a chuck to grip the coil core for winding, but any simple winder will work well.

The developer does the wire twisting by stretching out three strands of wire, each coming from a separate 500 gram reel of wire. The three strands are clamped at each end with the wires touching each other at each end and with three metres between the clamps. Then, the wires are clamped in the middle and 80 turns applied to the middle. That gives 80 turns for each of the two 1.5 metre lengths held between the clamps. The twisted wire is wound on to a makeshift reel to keep it tidy as this twisting has to be repeated 46 more times as the entire contents of the reels of wire will be needed for this one composite coil:



The next 3 metres of the three wires is now clamped and 80 turns applied to the central point, but this time the turns are applied in the opposite direction. Still the same 80 turns, but if the last length was 'clockwise' then this stretch of wire will be turned 'counter-clockwise'. This alternation of direction gives a finished set of twisted wires where the direction of twist reverses every 1.5 metres along the length. That is the way that commercially produced Litz wire is made.

This very nice twisted group of wires is now used to wind the coil. A hole is drilled in one spool flange, right beside the central tube and core, and the start of the wire fed through it. The wire is then bent sharply at 90 degrees and fed around the shaft of the spool to start the winding of the coil. The wire bundle is wound carefully side by side along the length of the spool shaft and there will be 51 turns in each layer and the next layer is wound directly on top of the first layer, moving back towards the start. Make sure that the turns of this second layer sit exactly on top of the turns beneath them. This is easy to do as the wire bundle is thick enough to make positioning very easy. If you prefer, a single thickness of white paper can be placed around the first layer, to make it easier to see the second layer as it is wound. There will be 18 of these layers to complete the coil, which will then weigh 1.5 kilograms and the winding looks like this:

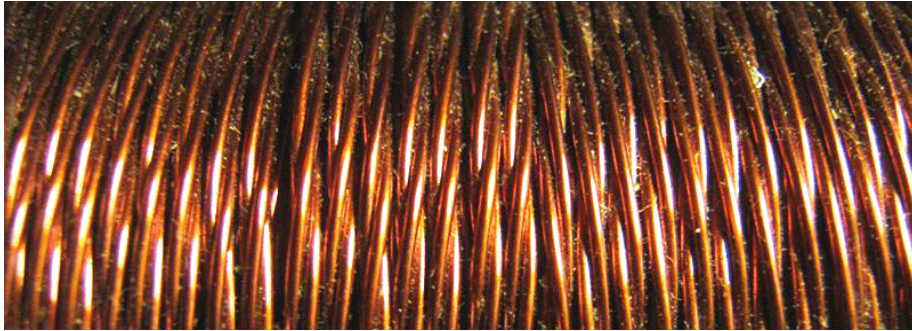

This completed coil now contains three separate coils in very close proximity to each other and that arrangement is excellent for inducing energy in the other two coils, when one of the coils is powered up. This winding now contains coils 1,2 and 3 of the circuit diagram. There is no need to concern yourself with marking the ends of each strand of wire as a simple ohmmeter will tell you which two ends have a connection between them.

Coil 1 is used as the trigger coil which switches the transistor on at the right instant. Coil 2 is the drive coil which is powered by the transistor, and Coil 3 is the first of the output coils:

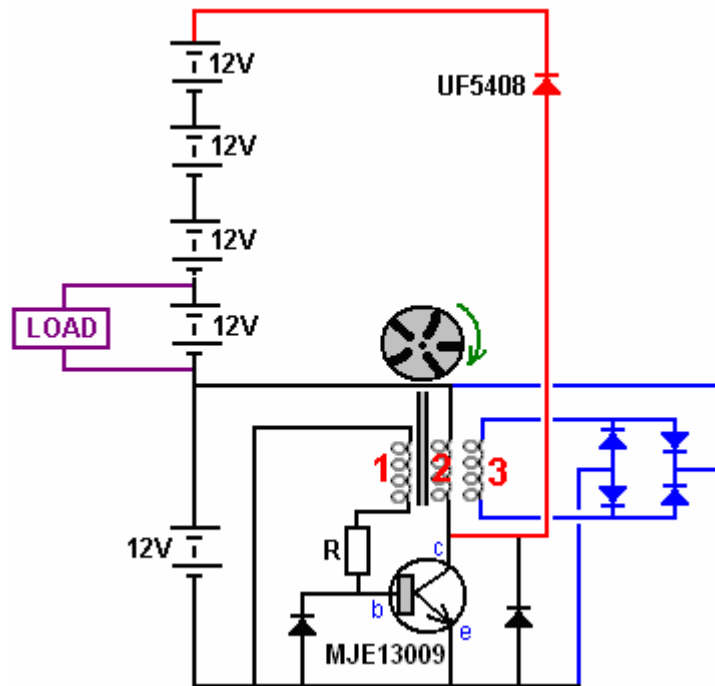

Because of the coils which were already to hand during the development of this highly successful system, coils 4 and 5 are simple helical-wound coils which are wired in parallel with drive coil 2. They boost the drive and they are necessary. Coil 4 has a DC resistance of 19 ohms and coil 5 a resistance of 13 ohms. However, investigation is underway at present to determine the best coil combination for this generator and it is probable that the additional coils will be the same as the first coil, coil "B" and that all three coils are connected in the same way and the driving winding in each coil driven by the one powerful, fast transistor. The present arrangement looks like this:

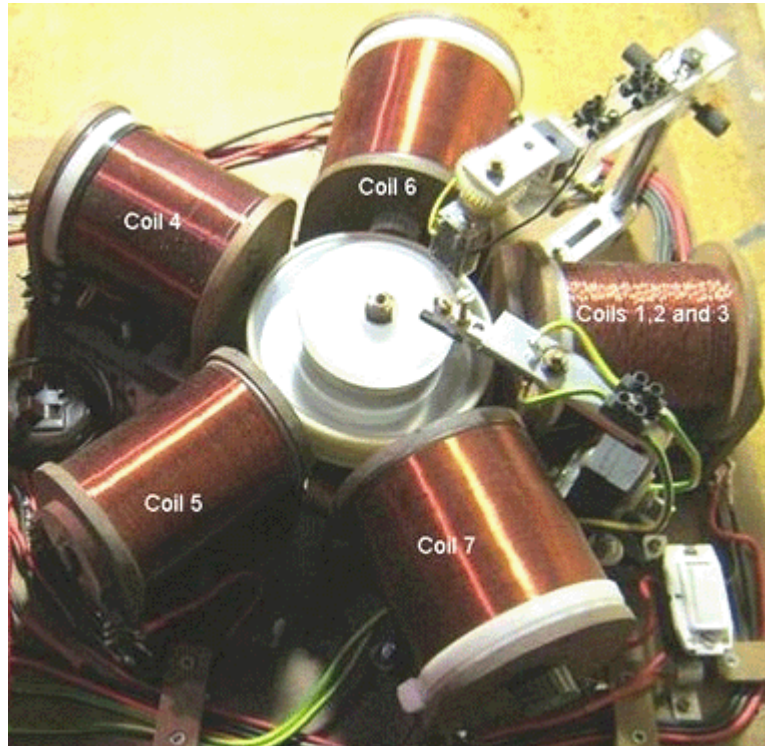

The two gantries can be ignored as they were only for investigating alternative ways of triggering the transistor and they are no longer used.

At this time, coils 6 and 7 (22 ohms each) are extra output coils connected in parallel with output coil 3 which is 3 strands each with 4.2 ohm resistance. They can be air-core or have a solid iron core. Testing indicates that the air-core version works slightly better than having an iron core. These two coils are wound on 22 mm diameter spools and each has 4000 turns of 0.7 mm (AWG # 21 or swg 22) enamel or shellac insulated solid copper wire. All of the coils are wound with this diameter of wire.

With this coil arrangement, the prototype has run continuously for three weeks, maintaining the drive battery at 12.7 volts all the time. At the end of the three weeks, the system was stopped so that it could be altered and tested with a new configuration. In the configuration shown above, the current flowing from the driving battery into the circuit is 70 milliamps, which at 12.7 volts is an input power of 0.89 watts. The output power is either 40 watts or close to it, which is a COP of 45, not counting the fact that three additional 12V batteries are being charged at the same time. That is very impressive performance for the circuit.

The drive method has been used so often by John Bedini, that the developer decided to try out John's method of tuning for maximum performance. However, it was eventually found that a Hall-effect semiconductor exactly aligned with a magnet gives the best results.

Further development of the circuit continues and the power output has now reached 60 watts. This is impressive for such a small device, especially when you consider that there is no practical input. For this next step the number of batteries has been reduced to just one. Here is the circuit:

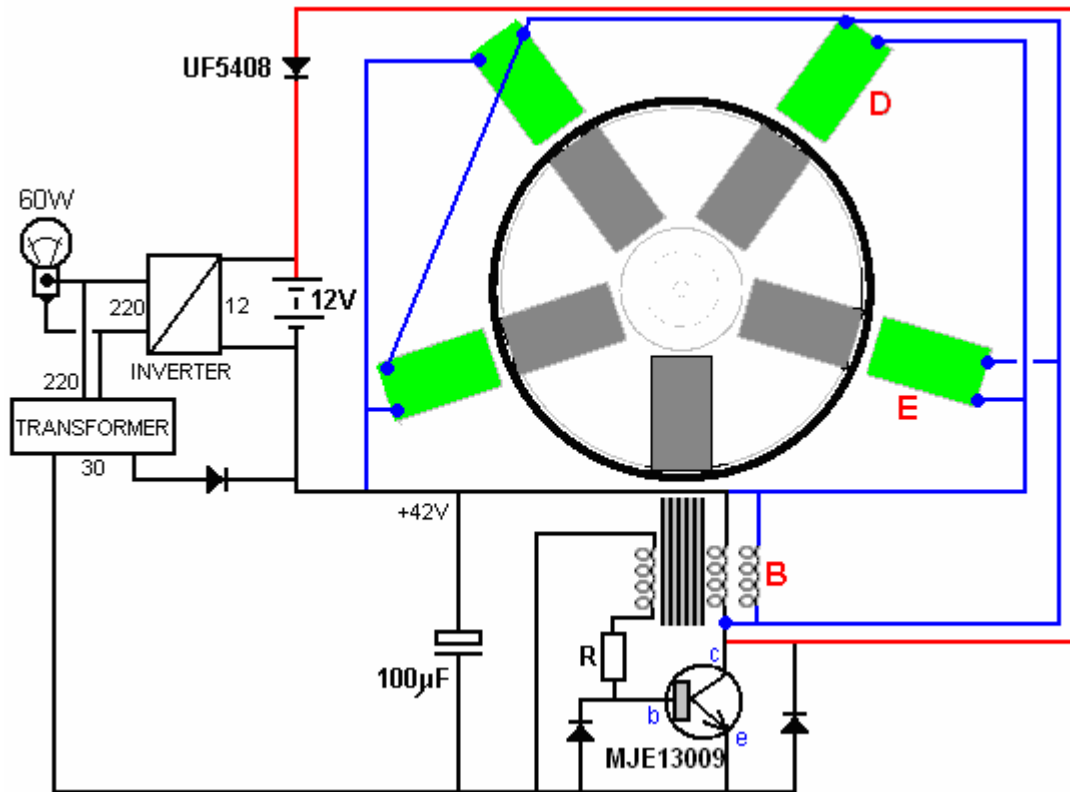

In this arrangement, coil "B" is also pulsed by the transistor and the output from the coils around the rotor is now directed to the output inverter. The drive battery has been eliminated and a low-power 30V transformer and diode run from the inverter output to replace it. Spinning the rotor generates sufficient charge on the capacitor to get the system running without a battery. The output power has now risen to 60 watts which is a 50% improvement. The three 12-volt batteries have also been eliminated, and the circuit can run with just one battery. Continuous power output from a single battery which never needs to be recharged is a very satisfactory situation.

The next advance is a circuit arrangement using a Hall-effect sensor and an FET transistor. The Hall-effect sensor is aligned exactly with the magnets. That is, the sensor is positioned between one of the coils and the rotor magnet. There is a 1 mm clearance between the sensor and the rotor and the arrangement looks like this:

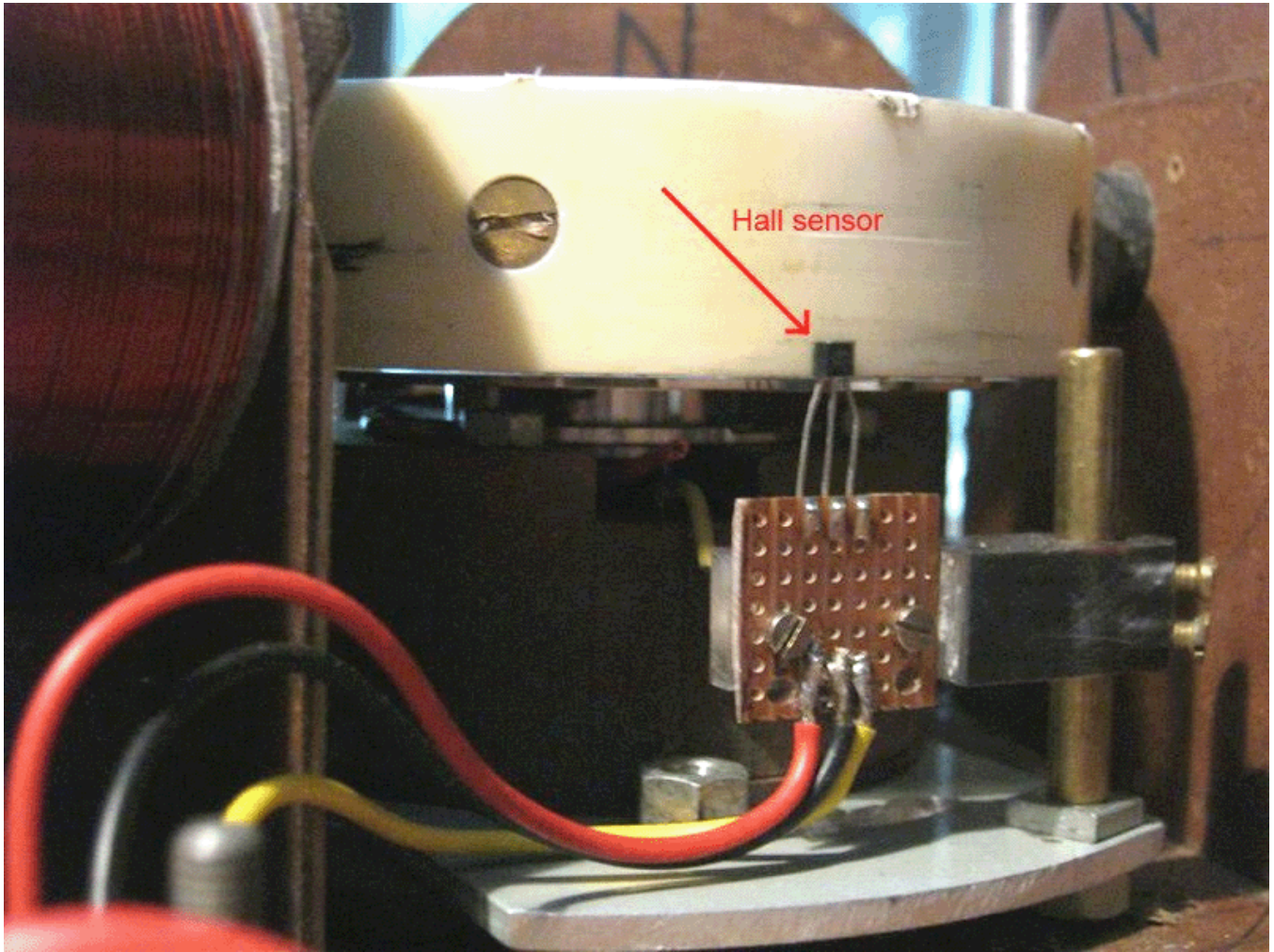

Or when the coil is in position, the view from above is like this:

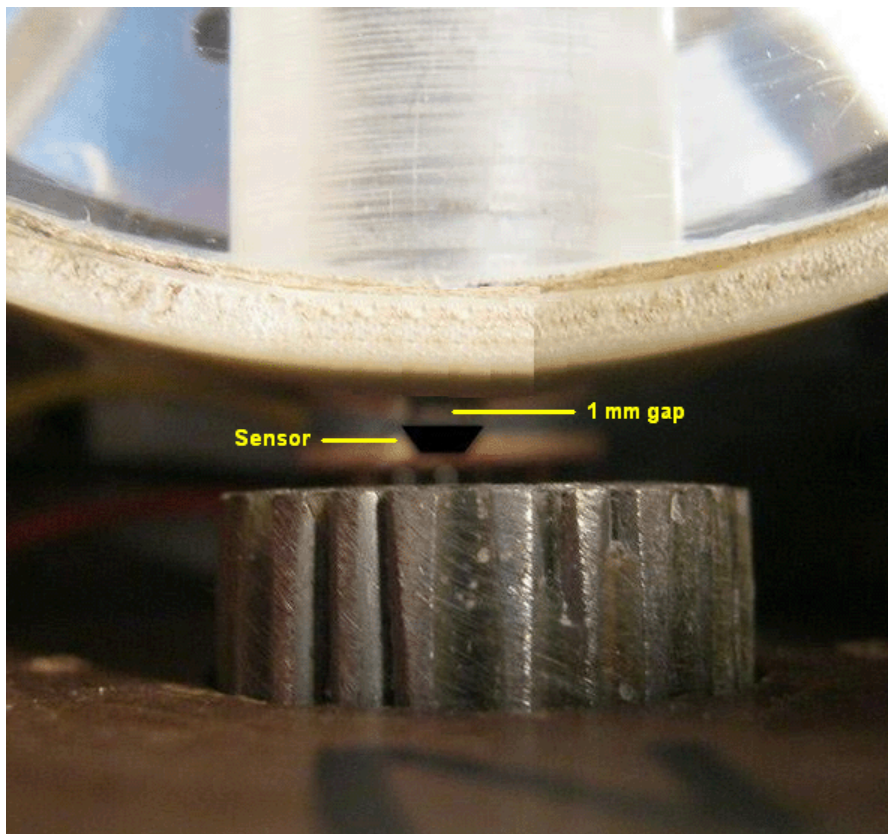

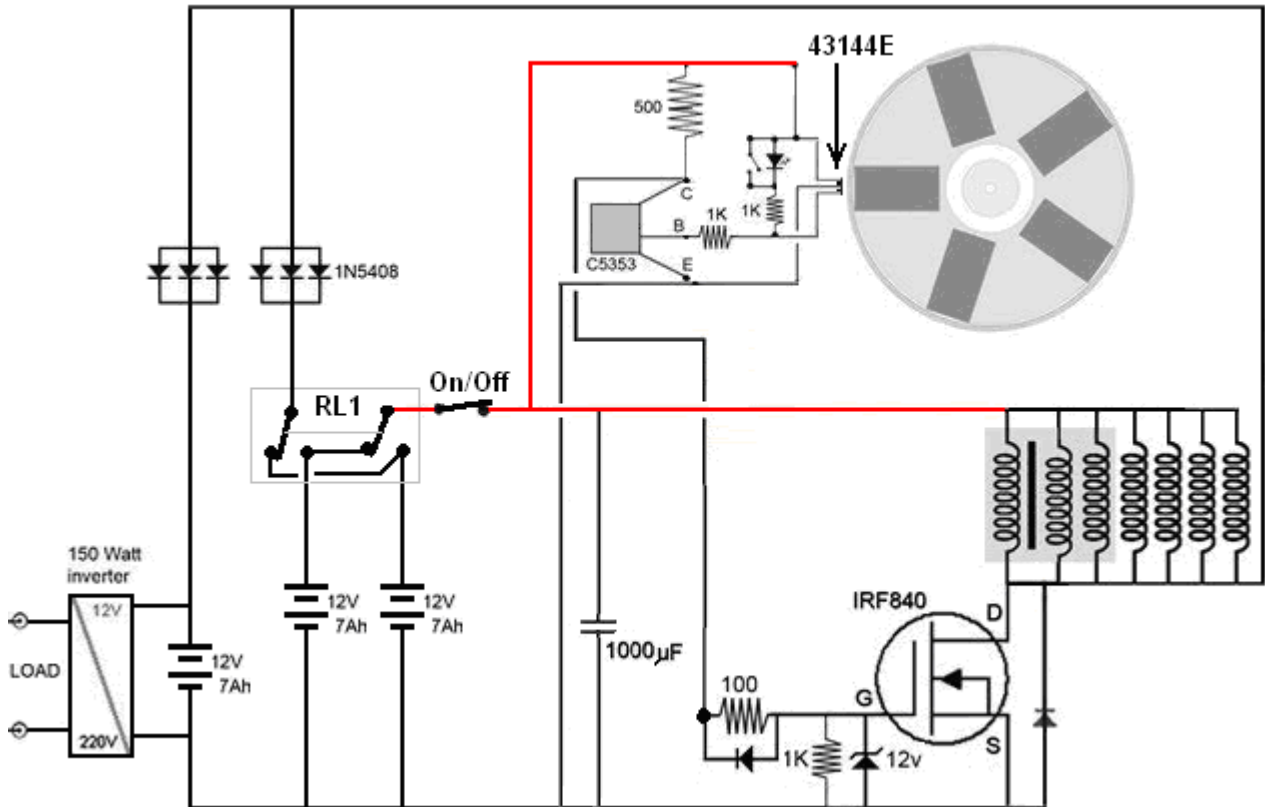

This circuit has a 150 watt continuous output and it uses three 12-volt batteries. The first two batteries are used, one to power the circuit while the second one is being recharged through three diodes wired in parallel to improve the recharging current flow. The two-pole two-way changeover switch "RL1" swaps the batteries over every few minutes using the circuit shown below. This technique keeps both batteries fully charged.

The recharging current also flows through a second set of three diodes wired in parallel, recharging the third 12-volt battery which powers the inverter which supplies the load. The test load was a 100-watt bulb and a 50-watt fan.

The Hall-effect sensor drives a C5353 transistor but any fast-switching transistor such as a BC109 or a 2N2222 transistor can be used. You will notice that all of the coils are now being driven by the IRF840 FET. The relay used for the switching is a latching type such as this one:



And it is driven by a low current draw ILC555N timer like this:

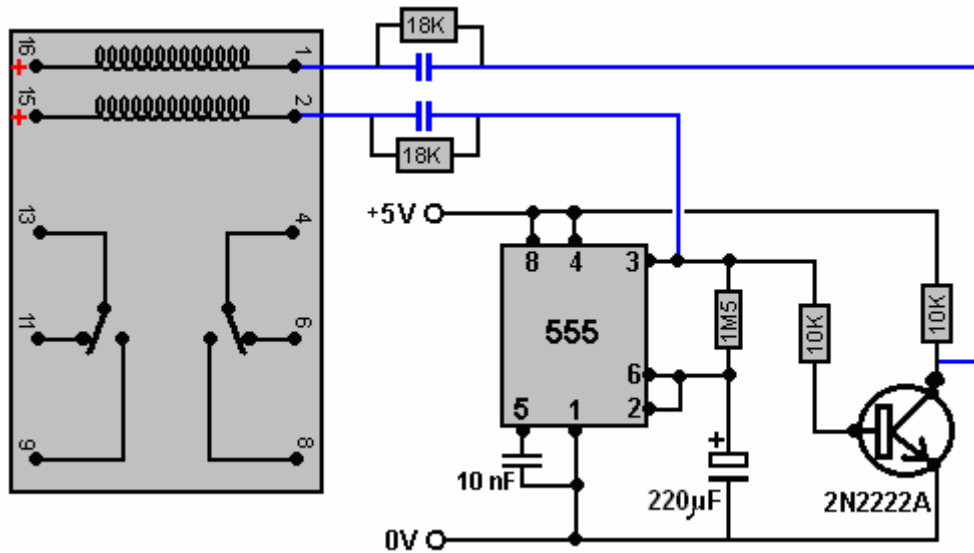

The capacitors shown in blue are chosen to operate the actual physical relay which is used in the circuit. They give the relay a brief switching pulse every five minutes or so. The 18K resistors across the capacitors are to bleed off the capacitor charge during the five minutes when the timer is in its alternative state.

However, if you wish to avoid switching between batteries, the circuit can be arranged this way:

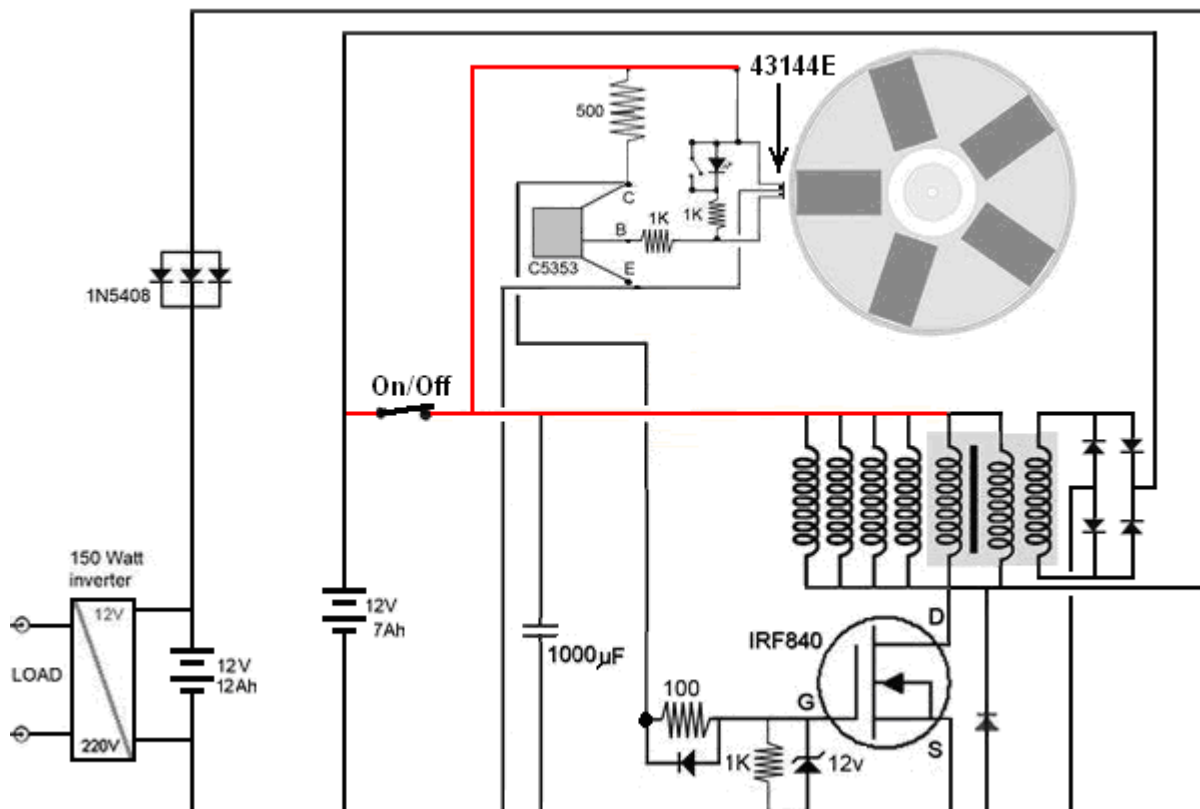

Here, the battery which powers the inverter which supplies the load is increased in capacity and while the developer used two of his 7 Amp-Hour batteries, you can use a standard 12-volt 12 Amp-Hour battery intended for a mobility scooter. All but one of the coils is used to supply current to the output battery and the one remaining coil, which is part of the three-strand main coil, is used to supply the drive battery directly.

The 1N5408 diode is a 100-volt 3-amp component. The diodes which are not shown with a type number against them can be any diode in the 1Nxxx range of diodes. The coils shown connected to the IRF840 FET transistor are physically positioned around the circumference of the rotor. There are five of these coils as the grey shading indicates that the righthandmost three coils are the separate strands of the main 3-wire composite coil which was shown in the earlier circuits.

While the three-strand twisted wire coil prepared for the Bedini-style switching was used for both drive and output purposes, it was actually no longer necessary to use a coil of that type and an ordinary helically

wound coil containing 1500 grams of 0.71 mm diameter enamelled copper wire would have been just as effective. Development has been continuing and the following circuit has been found to work very well:

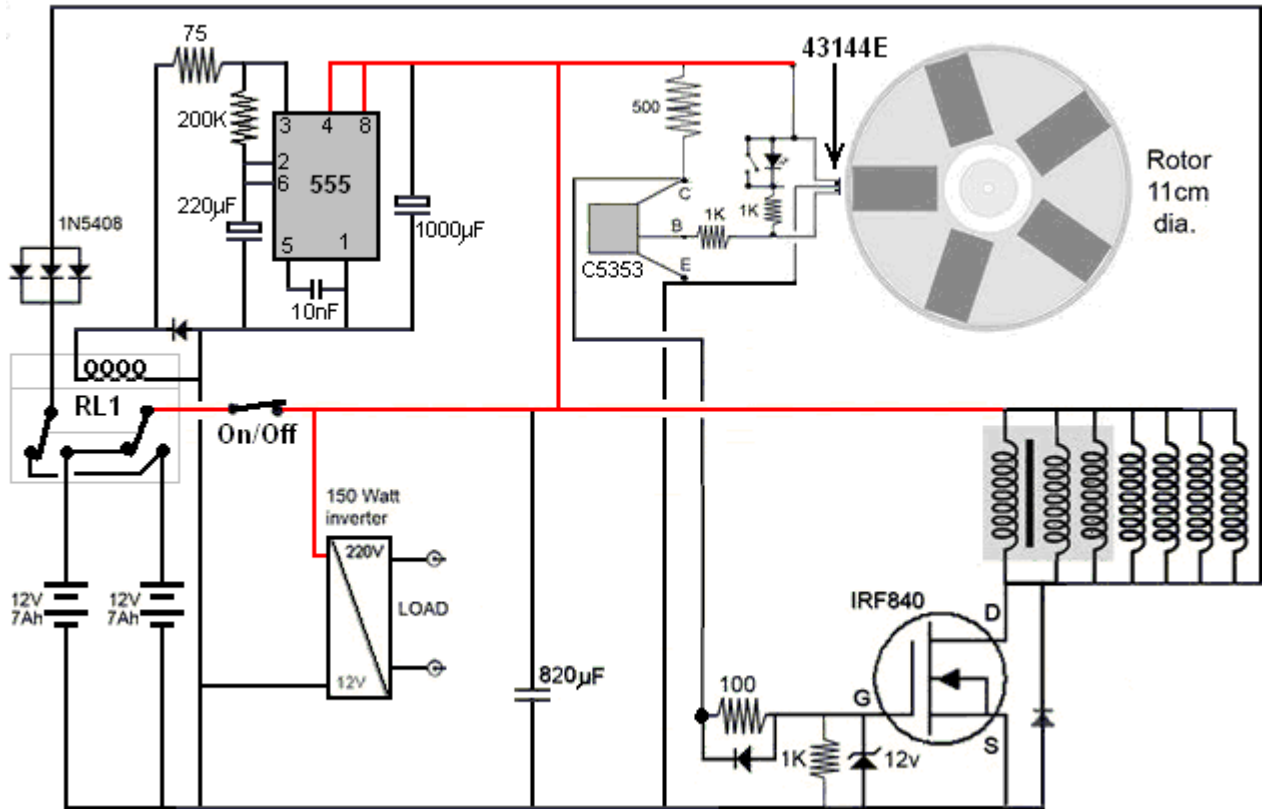

In this version of the circuit, a 12-volt non-latching relay is used. The relay normally draws 100 milliamps at 12 volts but a 75 ohm or a 100 ohm resistor in series lowers that current to about 60 milliamps. That current is only drawn for half the time as the relay is not powered up when the “normally closed” contacts are being used. The system powers itself very satisfactorily as before.

However, the South African developer would very much like to omit the mains inverter, and so he prefers the following arrangement. This version powers the drive circuitry through an ordinary DC-to-DC inverter which provides additional voltage to the IRF840 transistor and the circuit works very well with this configuration:

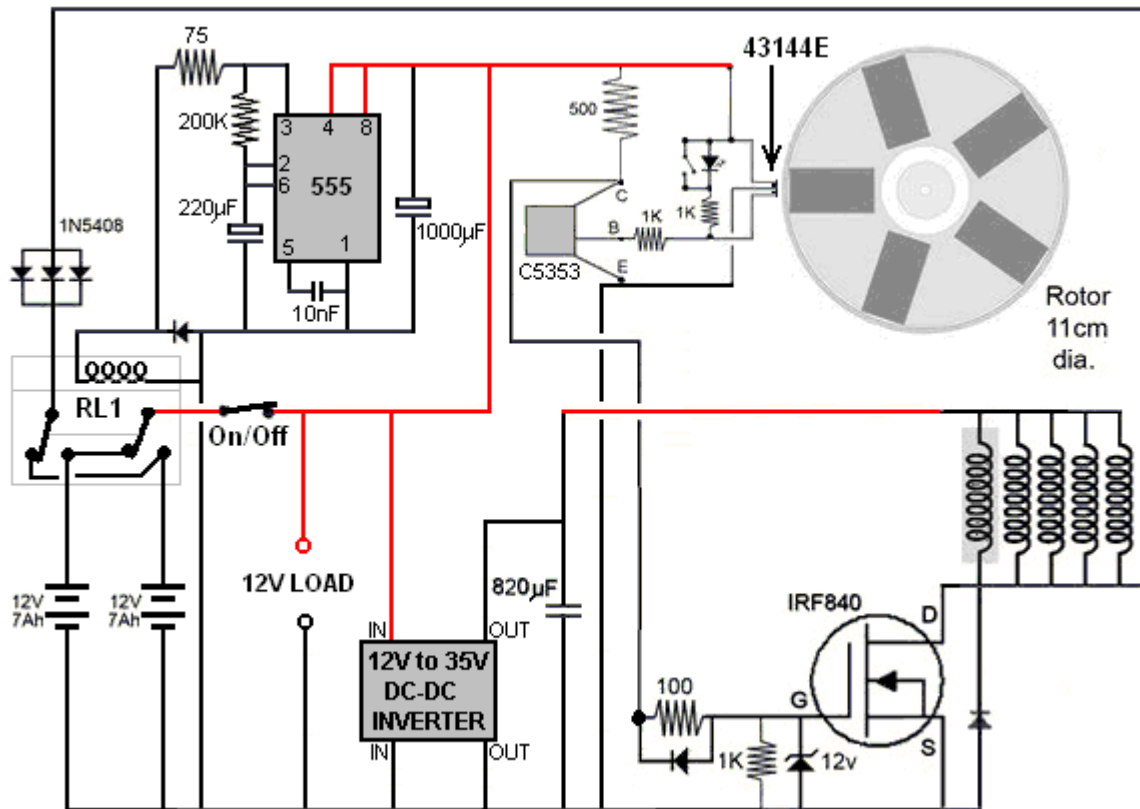

The developer stresses that the circuit operates in a non-intuitive way. First, the performance is somewhat reduced if the rotor spins faster which is something which is not at all obvious. Then it has been found that using ferrite magnets produces a better performance than using the stronger neodymium magnets. He sees it as the coil pulses being a mechanism for preventing 'cogging' or backward drag on the passing rotor magnets.

This is the same thing that Robert Adams found with his high performance motor/generator. In Robert's design, the rotor was drawn to the iron cores of his coils, making his motor essentially a permanent magnet motor. Admittedly, Robert's rotor got additional thrusts from the current in his output coils being switched off at exactly the correct instant, but that involved a somewhat higher level of design complexity. While there is no official claim that this South African design is actually a permanent magnet motor/generator, it is difficult not to see some of its performance coming directly from the magnets themselves.

Finally, the design which the designer likes best of all is this one which has no inverter or converter and which can power any ordinary 12-volt load:

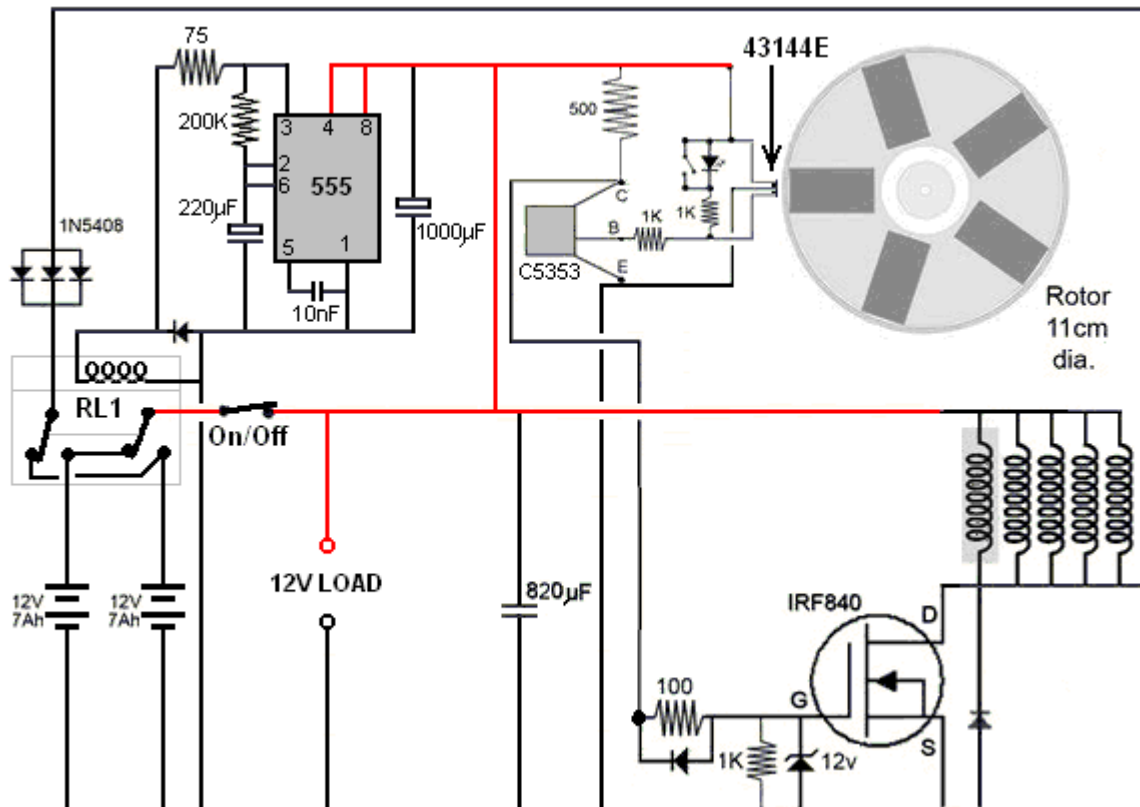

The output (marked as "12V Load") is effectively a 12-volt battery which never needs recharging and which can power any typical 12-volt small piece of equipment such as lighting, a fan, a laptop computer or whatever. You will notice that the triple coil is now shown as a single helically wound coil with a shaded background as there is no longer any need for a triple wound coil as the Bedini-style switching is no longer used. Let me stress that the five coils driven by the IRF840 FET transistor are shown in a horizontal row just for clarity. In reality, they are spaced out evenly around the rotor, that is, at 72-degree spacings around the rotor. There is nothing special about having five magnets in the rotor and that number could be six, eight, ten or twelve magnets if there is room for the corresponding coils around the rotor.

At the present time (April 2018), this is where the developer has reached and he considers the circuit shown above to be very satisfactory for his needs. So, let me (Patrick Kelly) make some untested suggestions which are intended to be helpful for replicators of the design. The rotor spins fast at about 2500 rpm (varying from 2000 to 3000 rpm depending on load and supply voltage). That is about 42 revolutions per second. As there are five magnets in the rotor, that produces about 208 pulses per second.

It is essential that the rotor itself is made very accurately so that there is no imbalance and so no vibration forces are generated by the rotation. The developer used a lathe to produce a perfect rotor but that option is not generally available to most people. I suggested casting a rotor using epoxy resin but it was pointed out that you have to have an exactly horizontal surface for that or the rotor will have an uneven thickness which would be disastrous. If you have access to a large 3D printer, a good rotor could be built up. One replicator shows his rotor like this:



This one is made in two halves which are then bolted together.

However, you might consider using a product which is manufactured for something else. The front wheel for a child's bicycle might prove to be suitable:



Front Wheel 12 1/2X 2 1/4 Plastic Black

Product Model:106838

£ 12.16

1

Order now!

✓ In Stock +/- 2 Business Days



Bike Original Front Wheel
14-inch With Nut

£19.12 New

The axle is supported on ball-race bearings and these wheels are generally made with precision. We would like a larger diameter than the original 110 mm diameter, because it seems likely that adding additional magnets and their associated coils would give a larger power output. There is no physical space for extra coils with an 110 mm diameter rotor, so an increased size seems like a reasonable alternative. However, there is no substitute for building and testing any proposed alternative design. The magnets can be attached to the rim of the wheel using duct tape with two or three complete turns around the rim and the magnet. Initially, there could be five magnets as before, but there is now space for an 8 magnet, 10 magnet

or 12 magnet rotor where the magnets are evenly spaced around the rotor which could be mounted with a horizontal axle as the wheel designers expected. Again, each coil is mounted with position-adjustment slots as before:

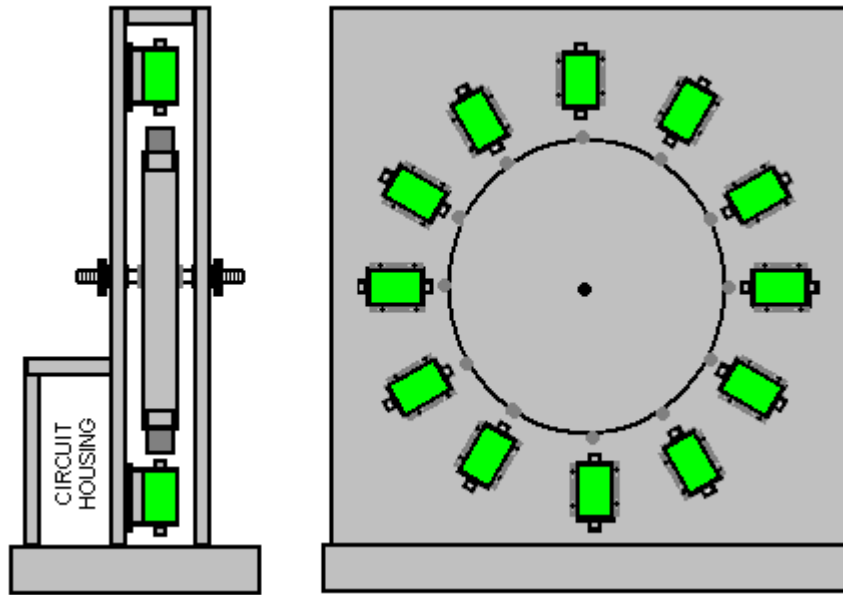

If extra magnets and coils are used, then the circuit might then be this:

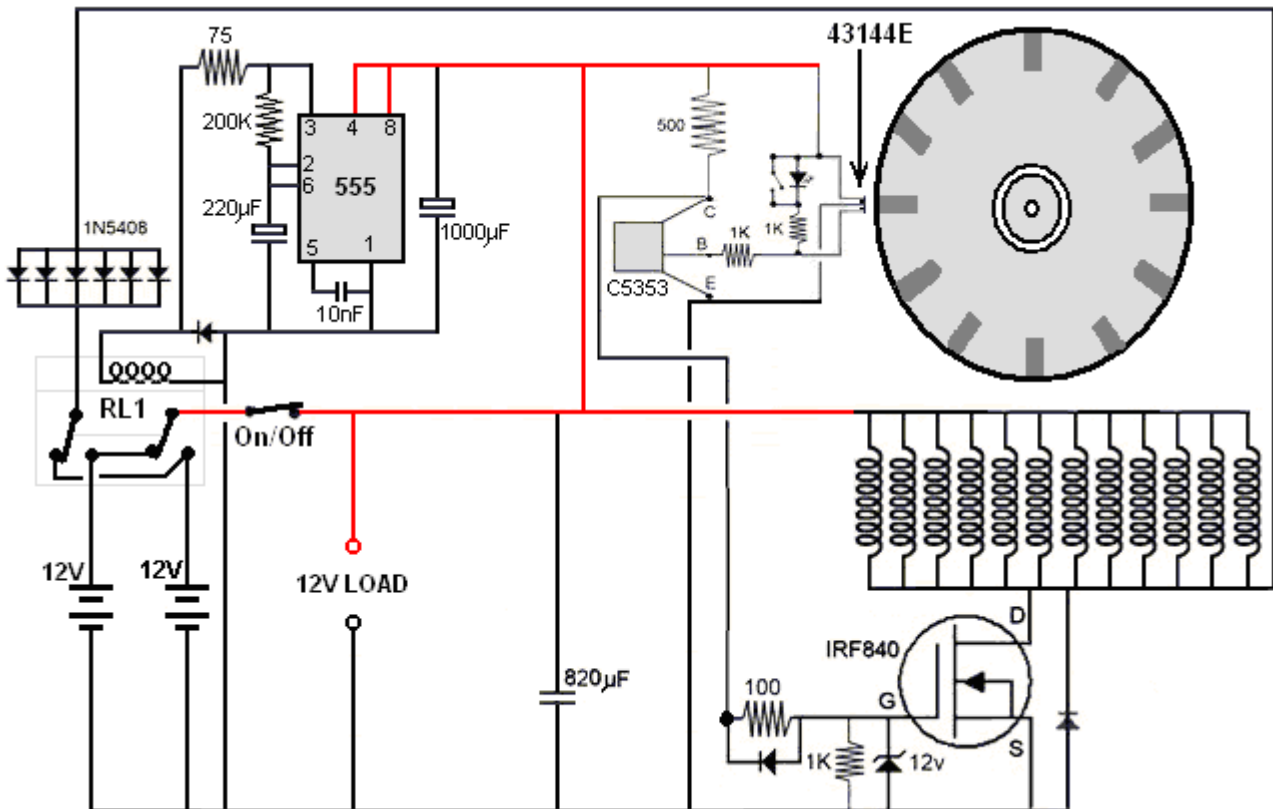

You will notice that the number of 1N5408 diodes has been doubled to allow an easier flow of increased current to the battery being charged. Please understand clearly that this last circuit is only a suggestion and has not been built and tested at the time of writing.

Video: www.youtube.com/user/TheEngpjk/videos