

The Buie-Morin Power System

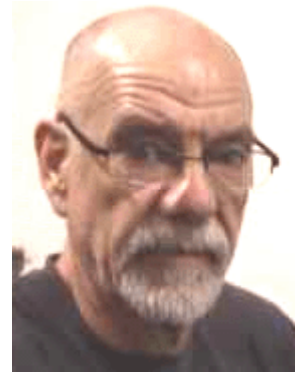

Thomas Buie of America and Gerard Morin of Canada both worked on developing a self-powered system which provides kilowatts of excess power to power other equipment. Thomas feels strongly that water and electricity are part of a person's rights and not a privilege which has to be paid for. They developed this self-powered generator in order to supply the electric needs of a household. First, we need to know what sort of power is used by typical household appliances. Perhaps this illustration might help:



Household power needs

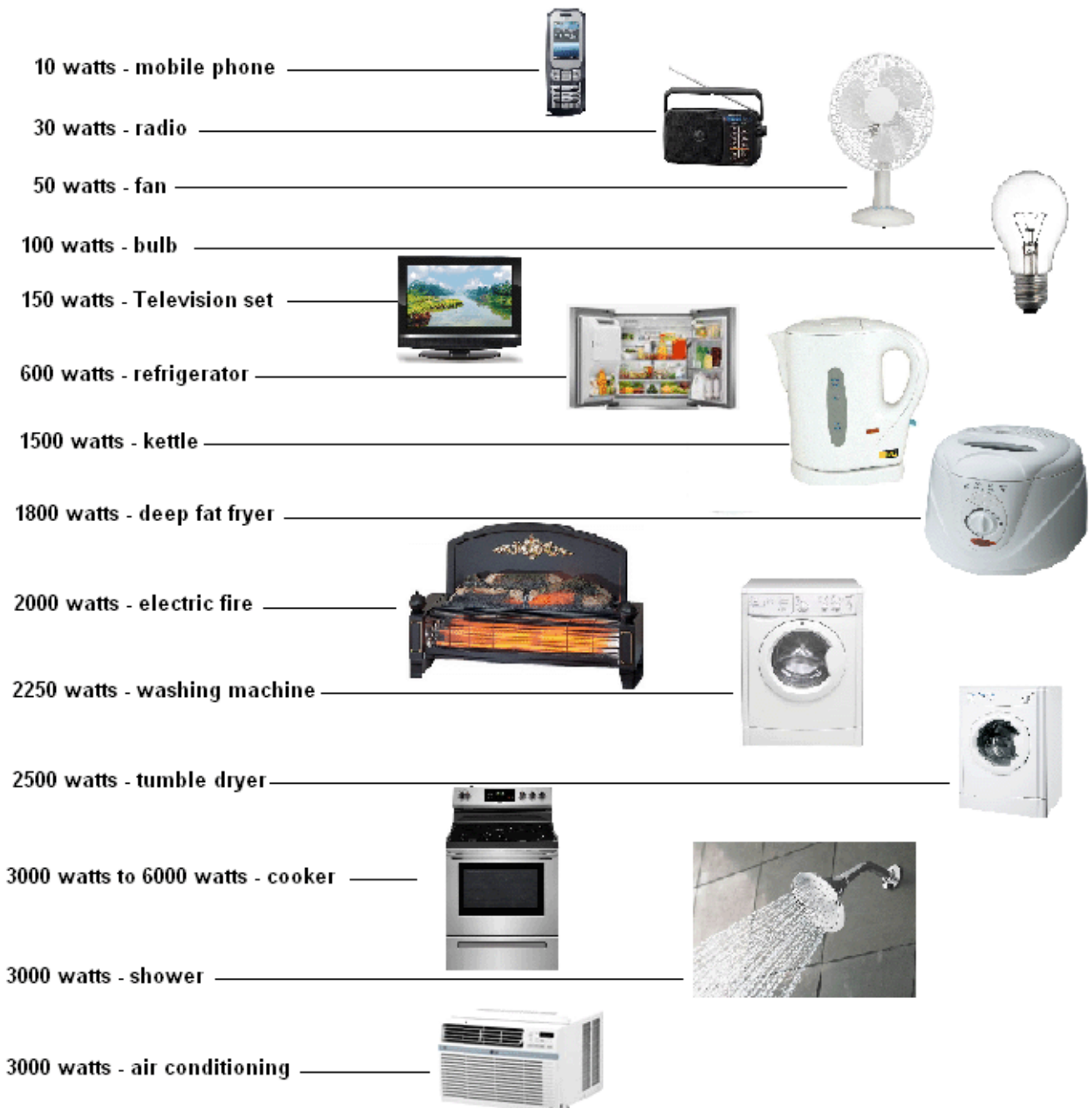

These power levels are only approximate as many devices have different power settings which the user can select. For example, in Iraq during the night, some households have communal air conditioning of only 1000 watts, Americans have daytime air conditioning of at least 3000 watts while in Britain almost no households have any kind of air conditioning, while some adults in India don't know what an electric fire is.

Anyway, it would be nice to be able to power electrical equipment without having to pay for electricity, and that is what this system allows you to do, whether it is the 120 volts 60 cycles per second used in America or the 240 volt 50 cycles per second used in the rest of the world.

The self-powered electricity generator which can provide you with free electricity is essentially very simple in outline. A battery is used to power a standard DC-to-AC inverter. Then the voltage is stepped up to around 400 volts. Next, a special controller is used to feed that 400 volts to a powerful motor at high frequency, and finally, the motor is used to spin an AC generator called an "alternator" which produces the electricity which we want. Part of that electricity is fed back to the battery and inverter input in order to make the system self-powered:

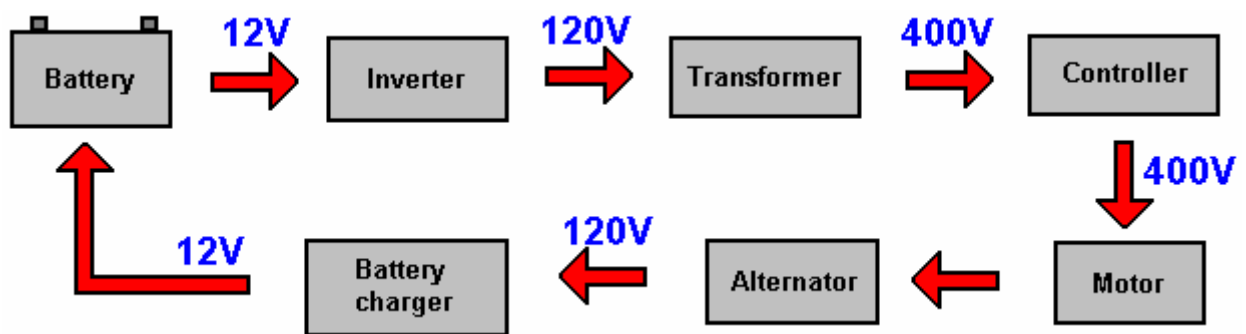

The "magic" is caused by the high voltage and the high speed pulses with which that voltage is applied to a carefully chosen type of motor. With 700 watts of input power, the system puts out 10,000 watts of power.

The most important components of this system are the controller and the motor. You are probably familiar with the most common type of motor which is a single-phase motor, but the more powerful motors used in industry are three-phase motors. There are several varieties of three-phase motors, but the one which we want to use has 36 coils connected as three sets of twelve windings in parallel:

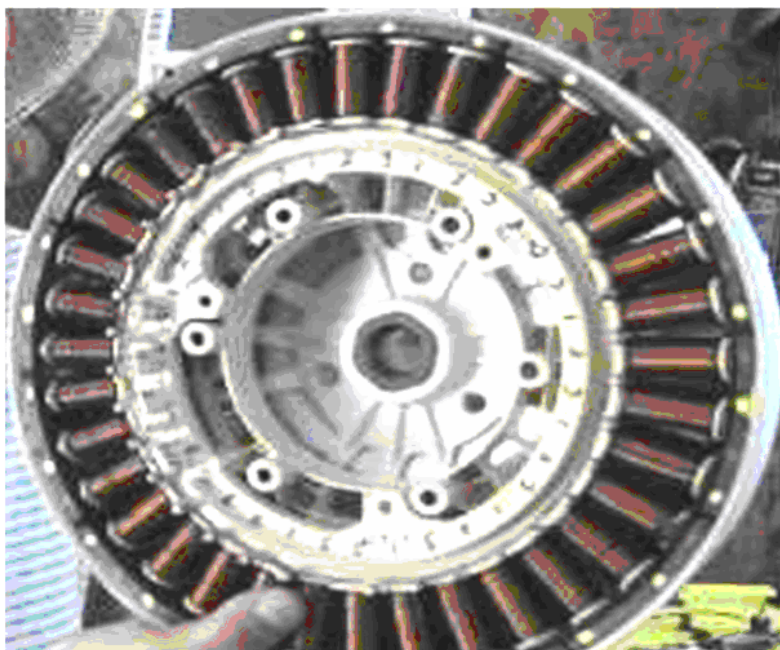

This is a very powerful arrangement as sending one pulse of current to each of these three chains, only advances the motor by 30 degrees. There is a continuous ring of magnets immediately outside the coils. This motor is used in a Samsung washing machine. A three-phase motor sounds very technical, but it really isn't. It is just a motor which has three sets of drive coils instead of just one coil:

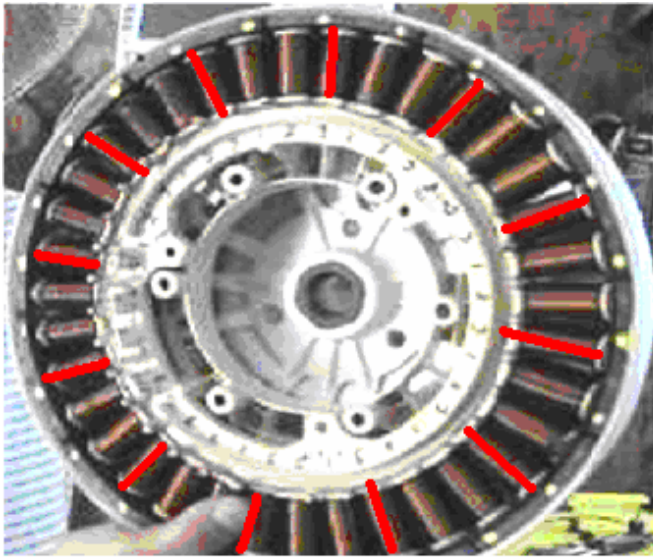

Coil set 1 is twelve coils all wired in parallel so that they act as a single coil

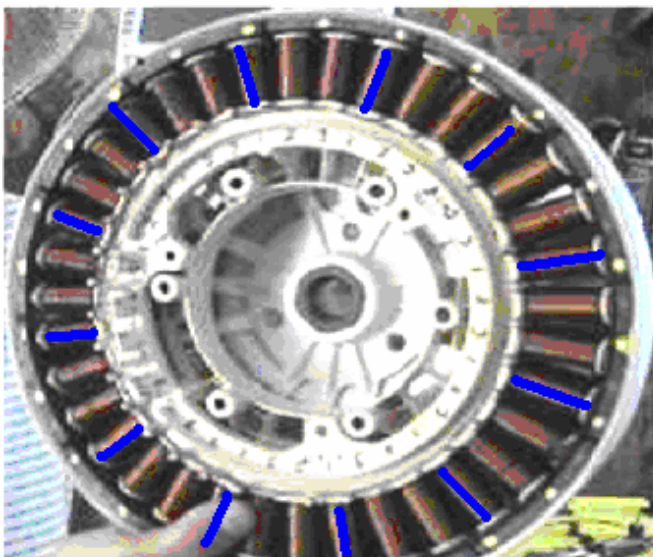

Coil set 2 is twelve coils all wired in parallel so that they act as a single coil

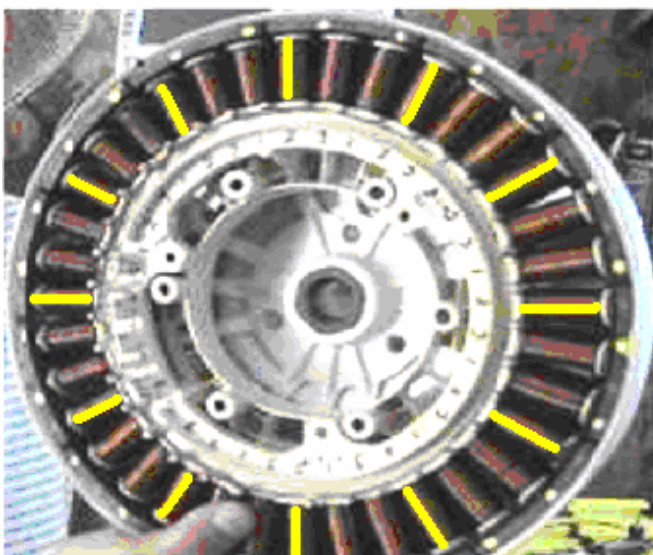

Coil set 3 is twelve coils all wired in parallel so that they act as a single coil

So, the motor has effectively just three coils in it and it is made to go round by pulsing the coils in order, that is coil 1, then coil 2, then coil 3, then coil 1 again and so on. The more rapidly the coils are pulsed, the faster the motor rotates, and in this system that rotation can be very fast indeed.

The pulsing of those three coils sets one after the other in sequence, is done by the “controller” unit which is a key component in this design. The motor is a permanent magnet, synchronous motor which has no sensors built into it. That sounds ever so impressive, but it is actually the cheapest type of three-phase motor, and because it has no sensors, it is the most difficult to drive reliably. There are several varieties of three-phase motors, but the one which we want to use has 36 coils connected as three sets of twelve coils in parallel.

The controller consists of two parts. The first is an Arduino board which is a general purpose development board - essentially a simple computer which can be programmed from an ordinary PC or laptop. It holds the program in its memory and runs it whenever it is instructed to do so. The second part is an electronics link between the Arduino board and the motor. That link boosts the power fed to the motor using high-power transistors which can feed high currents to the motor, and some other wires which feed information back to the Arduino board to give it full control of what is happening with the motor.

The Arduino program powers the motor coils in sequence and as well as that, it senses the position of the actual rotor as it spins. It does that by sensing the voltages in each of the three coil sets at all times.

At the web site here: <https://www.espare.co.uk/product/es1578438/washing-machine-motor?pageNumber=2&PartTypeId=1752&ManufacturerId=596> The motor is offered at £150 and here: <https://www.buyspares.co.uk/washing-machine/samsung/catalogue.pl?path=495970:496636,127481:496051&page=36> also at £150.

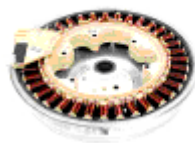

Samsung Motor

Genuine spare part



It is not necessary for you to become an expert programmer of an Arduino board as the program used is provided for you here. A good instruction video on programming the Arduino Uno board is shown here: <https://www.youtube.com/watch?v=5OtMqr5hGjE>.

The Arduino code is shown below is from <https://simple-circuit.com/arduino-sensorless-blcdc-motor-controller-esc/> but can be downloaded as a text file from: www.free-energy-info.com/Arduino.txt

```
1 // Sensorless brushless DC (BLDC) motor control with Arduino UNO (Arduino DIY ESC).
2 // This is a free software without any warranty.
3
4
5 #define SPEED_UP      A0
6 #define SPEED_DOWN    A1
7 #define PWM_MAX_DUTY  255
8 #define PWM_MIN_DUTY  50
9 #define PWM_START_DUTY 100
10
11 byte bldc_step = 0, motor_speed;
12 unsigned int i;
13 void setup() {
14   DDRD |= 0x38; // Configure pins 3, 4 and 5 as outputs
```

```

15 PORTD = 0x00;
16 DDRB |= 0x0E;      // Configure pins 9, 10 and 11 as outputs
17 PORTB = 0x31;
18 // Timer1 module setting: set clock source to clkI/O / 1 (no prescaling)
19 TCCR1A = 0;
20 TCCR1B = 0x01;
21 // Timer2 module setting: set clock source to clkI/O / 1 (no prescaling)
22 TCCR2A = 0;
23 TCCR2B = 0x01;
24 // Analog comparator setting
25 ACSR = 0x10;      // Disable and clear (flag bit) analog comparator interrupt
26 pinMode(SPEED_UP, INPUT_PULLUP);
27 pinMode(SPEED_DOWN, INPUT_PULLUP);
28 }
29 // Analog comparator ISR
30 ISR (ANALOG_COMP_vect) {
31 // BEMF debounce
32 for(i = 0; i < 10; i++) {
33   if(blde_step & 1){
34     if(!(ACSR & 0x20)) i -= 1;
35   }
36   else {
37     if((ACSR & 0x20)) i -= 1;
38   }
39 }
40 blde_move();
41 blde_step++;
42 blde_step %= 6;
43 }
44 void blde_move(){ // BLDC motor commutation function
45   switch(blde_step){
46     case 0:
47       AH_BL();
48       BEMF_C_RISING();
49       break;
50     case 1:
51       AH_CL();
52       BEMF_B_FALLING();
53       break;
54     case 2:
55       BH_CL();
56       BEMF_A_RISING();
57       break;
58     case 3:
59       BH_AL();
60       BEMF_C_FALLING();
61       break;
62     case 4:
63       CH_AL();
64       BEMF_B_RISING();
65       break;
66     case 5:
67       CH_BL();

```

```

68     BEMF_A_FALLING();
69     break;
70 }
71 }
72
73 void loop() {
74     SET_PWM_DUTY(PWM_START_DUTY); // Setup starting PWM with duty cycle =
75     PWM_START_DUTY
76     i = 5000;
77     // Motor start
78     while(i > 100) {
79         delayMicroseconds(i);
80         bldc_move();
81         bldc_step++;
82         bldc_step %= 6;
83         i = i - 20;
84     }
85     motor_speed = PWM_START_DUTY;
86     ACSR |= 0x08; // Enable analog comparator interrupt
87     while(1) {
88         while(!(digitalRead(SPEED_UP)) && motor_speed < PWM_MAX_DUTY){
89             motor_speed++;
90             SET_PWM_DUTY(motor_speed);
91             delay(100);
92         }
93         while(!(digitalRead(SPEED_DOWN)) && motor_speed > PWM_MIN_DUTY){
94             motor_speed--;
95             SET_PWM_DUTY(motor_speed);
96             delay(100);
97         }
98     }
99 }
100
101 void BEMF_A_RISING(){
102     ADCSRB = (0 << ACME); // Select AIN1 as comparator negative input
103     ACSR |= 0x03; // Set interrupt on rising edge
104 }
105 void BEMF_A_FALLING(){
106     ADCSRB = (0 << ACME); // Select AIN1 as comparator negative input
107     ACSR &= ~0x01; // Set interrupt on falling edge
108 }
109 void BEMF_B_RISING(){
110     ADCSRA = (0 << ADEN); // Disable the ADC module
111     ADCSRB = (1 << ACME);
112     ADMUX = 2; // Select analog channel 2 as comparator negative input
113     ACSR |= 0x03;
114 }
115 void BEMF_B_FALLING(){
116     ADCSRA = (0 << ADEN); // Disable the ADC module
117     ADCSRB = (1 << ACME);
118     ADMUX = 2; // Select analog channel 2 as comparator negative input
119     ACSR &= ~0x01;
120 }

```

```

121 void BEMF_C_RISING(){
122  ADCSRA = (0 << ADEN); // Disable the ADC module
123  ADCSRB = (1 << ACME);
124  ADMUX = 3;           // Select analog channel 3 as comparator negative input
125  ACSR |= 0x03;
126 }
127 void BEMF_C_FALLING(){
128  ADCSRA = (0 << ADEN); // Disable the ADC module
129  ADCSRB = (1 << ACME);
130  ADMUX = 3;           // Select analog channel 3 as comparator negative input
131  ACSR &= ~0x01;
132 }
133
134 void AH_BL(){
135  PORTB = 0x04;
136  PORTD &= ~0x18;
137  PORTD |= 0x20;
138  TCCR1A = 0;          // Turn pin 11 (OC2A) PWM ON (pin 9 & pin 10 OFF)
139  TCCR2A = 0x81;      //
140 }
141 void AH_CL(){
142  PORTB = 0x02;
143  PORTD &= ~0x18;
144  PORTD |= 0x20;
145  TCCR1A = 0;          // Turn pin 11 (OC2A) PWM ON (pin 9 & pin 10 OFF)
146  TCCR2A = 0x81;      //
147 }
148 void BH_CL(){
149  PORTB = 0x02;
150  PORTD &= ~0x28;
151  PORTD |= 0x10;
152  TCCR2A = 0;          // Turn pin 10 (OC1B) PWM ON (pin 9 & pin 11 OFF)
153  TCCR1A = 0x21;      //
154 }
155 void BH_AL(){
156  PORTB = 0x08;
157  PORTD &= ~0x28;
158  PORTD |= 0x10;
159  TCCR2A = 0;          // Turn pin 10 (OC1B) PWM ON (pin 9 & pin 11 OFF)
160  TCCR1A = 0x21;      //
161 }
162 void CH_AL(){
163  PORTB = 0x08;
164  PORTD &= ~0x30;
165  PORTD |= 0x08;
166  TCCR2A = 0;          // Turn pin 9 (OC1A) PWM ON (pin 10 & pin 11 OFF)
167  TCCR1A = 0x81;      //
168 }
169 void CH_BL(){
170  PORTB = 0x04;
171  PORTD &= ~0x30;
172  PORTD |= 0x08;
173  TCCR2A = 0;          // Turn pin 9 (OC1A) PWM ON (pin 10 & pin 11 OFF)

```

```

174 TCCR1A = 0x81;    //
175 }
176
177 void SET_PWM_DUTY(byte duty){
178   if(duty < PWM_MIN_DUTY)
179     duty = PWM_MIN_DUTY;
180   if(duty > PWM_MAX_DUTY)
181     duty = PWM_MAX_DUTY;
182   OCR1A = duty;      // Set pin 9 PWM duty cycle
183   OCR1B = duty;      // Set pin 10 PWM duty cycle
184   OCR2A = duty;      // Set pin 11 PWM duty cycle
  }

```

The Arduino board looks like this:

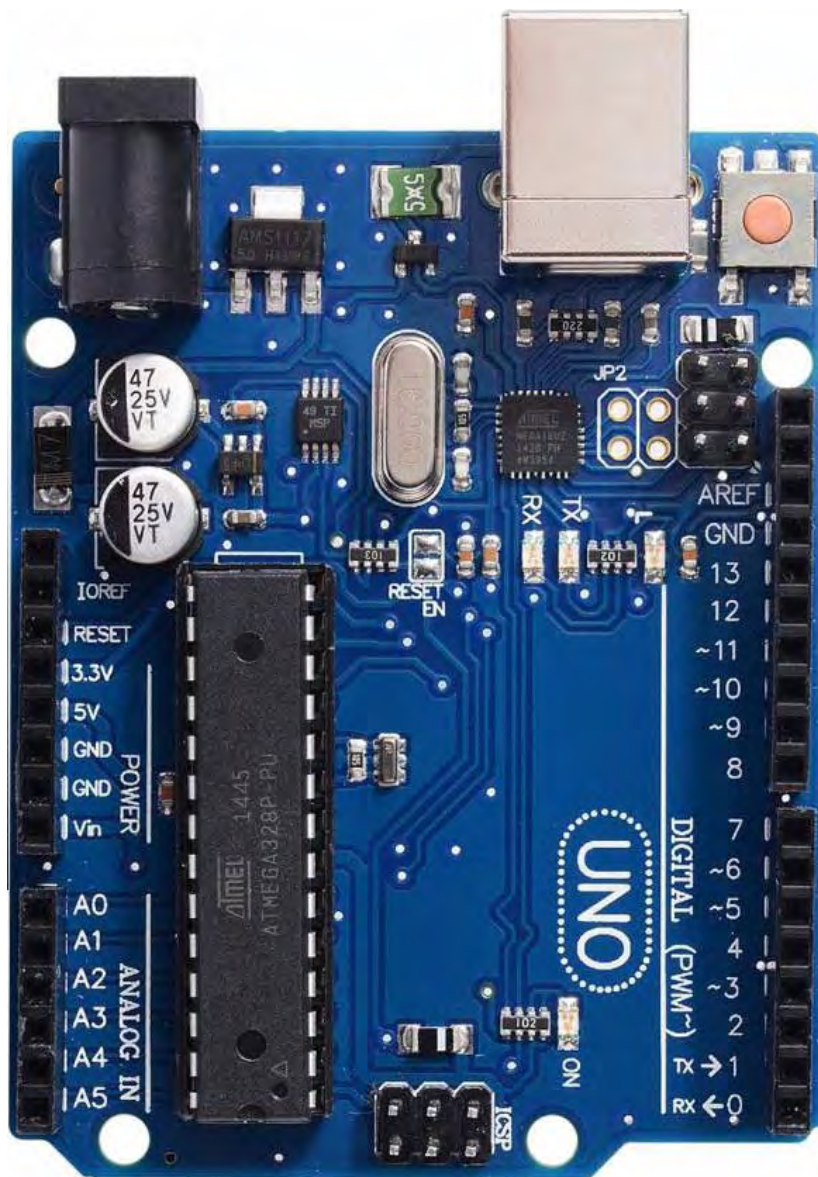

IR2104

The interface between the Arduino Uno board and the motor, needs the following components:

- 6 x IRF840 FET transistors
- 3 x IR2104 DIP gate driver IC
- 6 x 33k ohm 5 watt ceramic resistors
- 3 x 10k ohm 5 watt resistors
- 6 x 100 ohm quarter watt resistors
- 3 x IN4148 diode
- 3 x 10uF 25 volt capacitors.
- 3 x 2.2uF 25 volt capacitors.
- 2 x pushbuttons
- 12V source
- Construction board and connecting wires

These components are connected up like this:

We need to connect this Arduino Uno up to drive one of the three phases of our three-phase motor, so to do that we will use an IR2104 driver chip and an IRF840 Field Effect Transistor (“FET”) to feed our 400 volt power supply to the motor at some 14,800 pulses per second. So, the power drive for the first phase is like this:

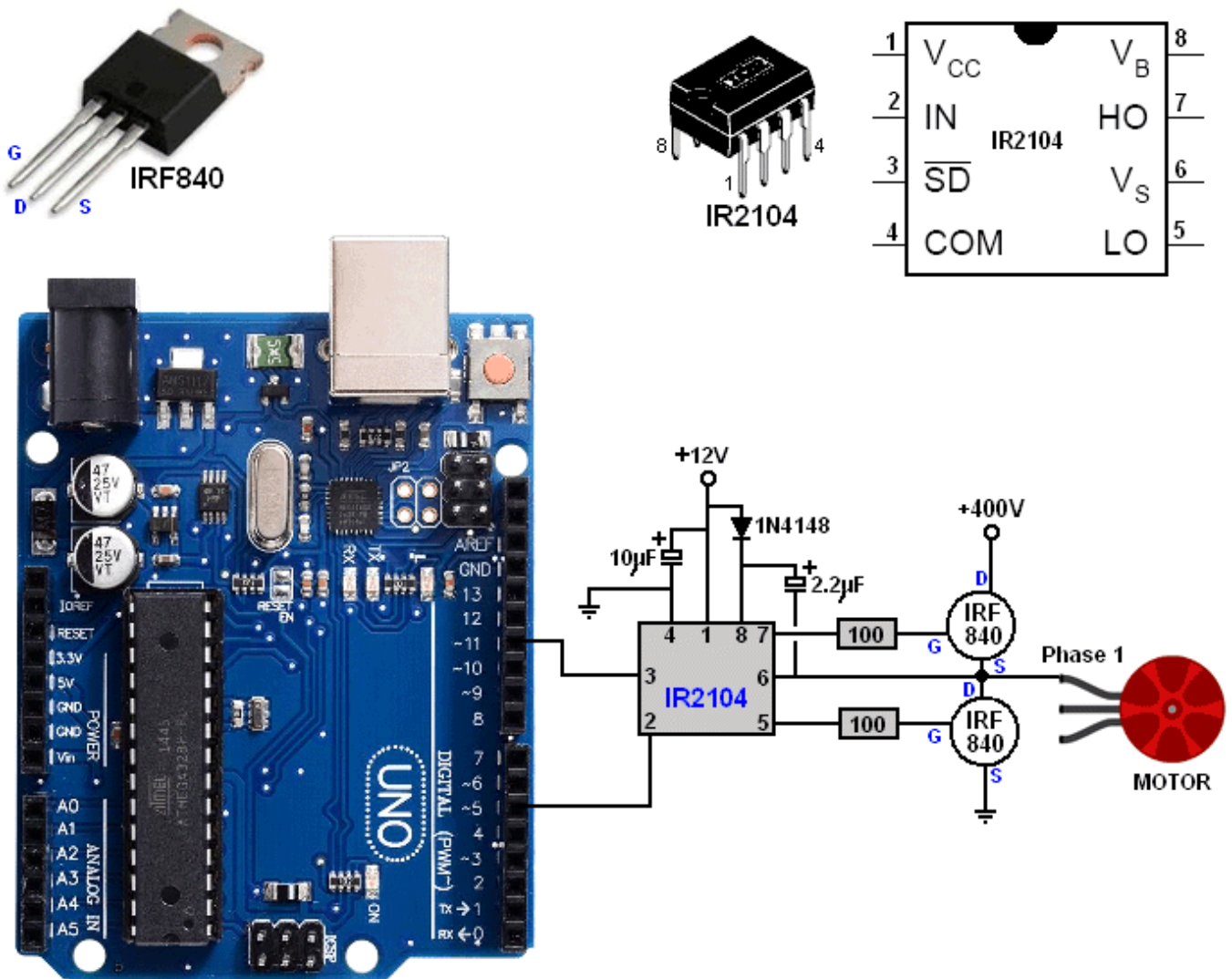

The 1N4148 diode is very fast operating with a 4 nanosecond time period. Because of its high performance, so many are made that it is also very cheap. The power drive for the second phase is:

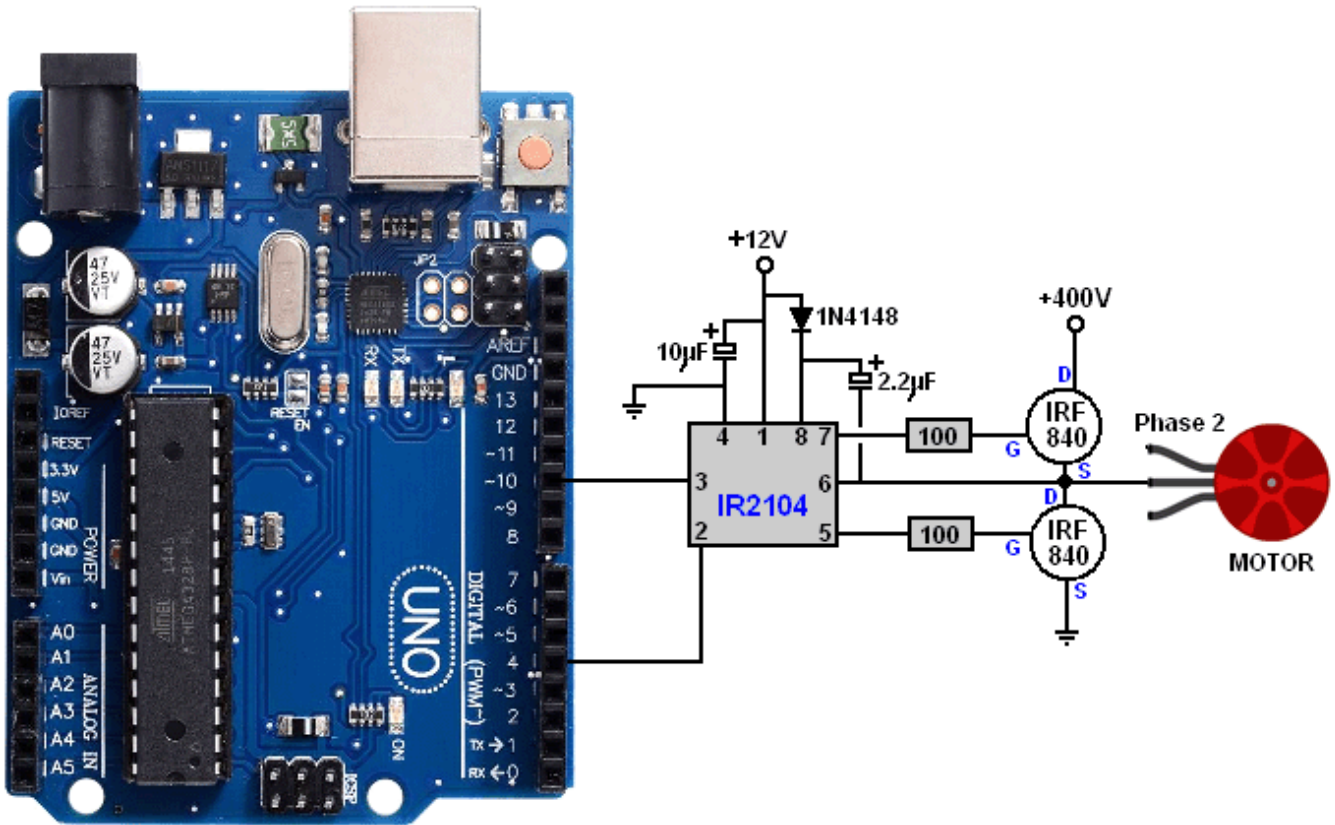

And the Power drive for the third phase is:

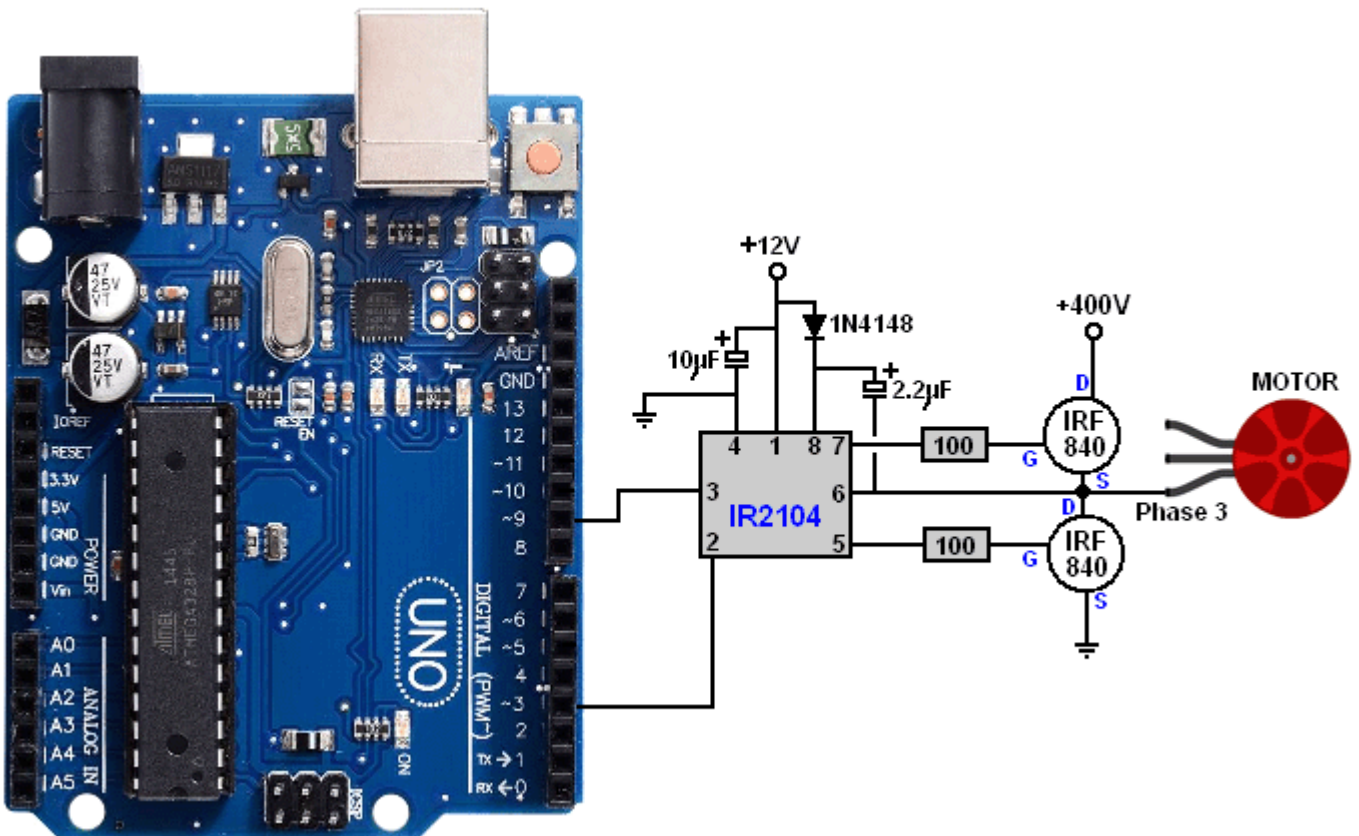

But we also need to provide the Arduino board with feedback information to let it know where the motor is in its rotation. That is done by sensing the Phase connections to the motor like this:

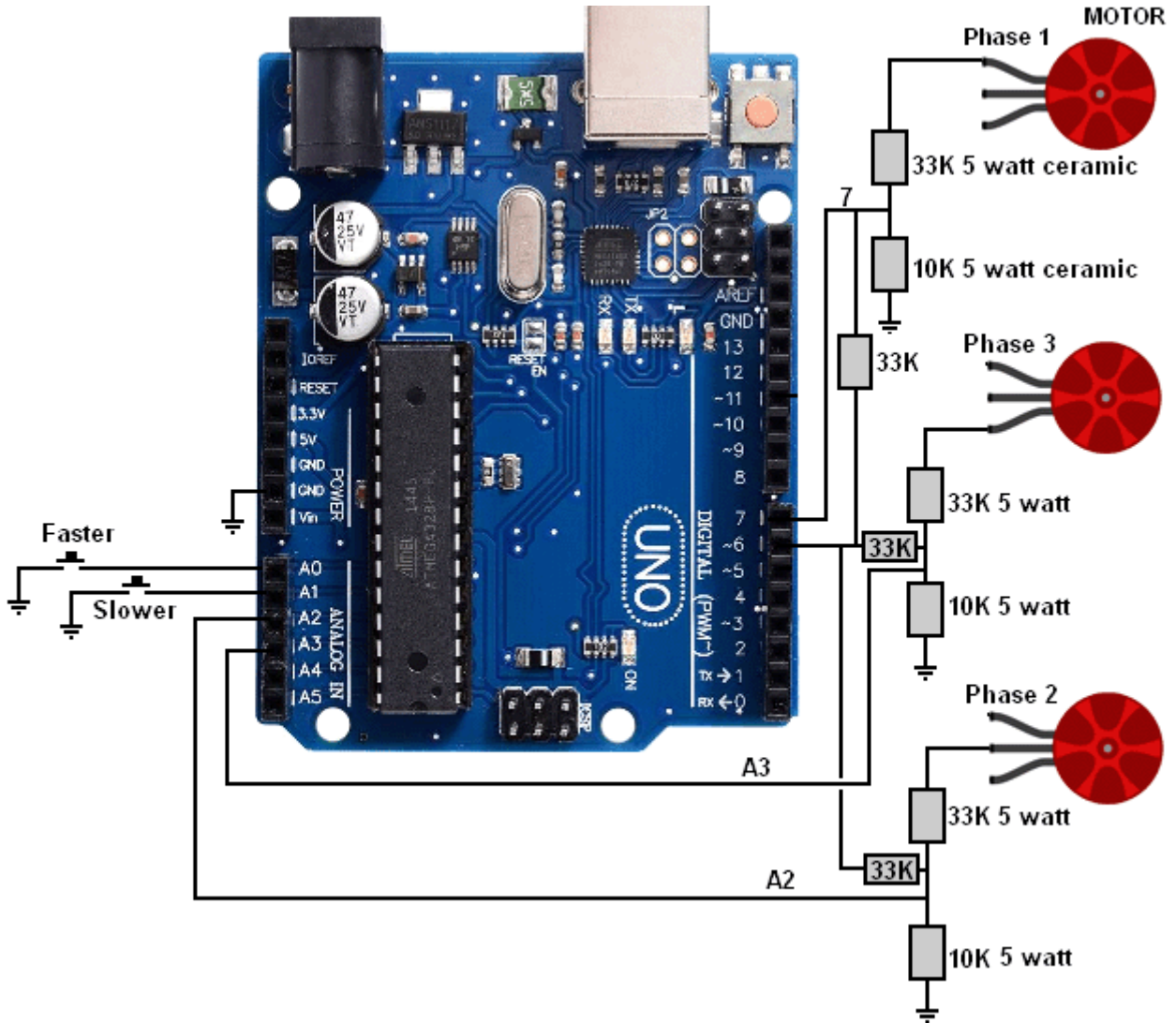

First, a word of warning here. You can get a shock from any voltage above 30 volts. If the voltage is Alternating Current at a frequency under 100 cycles per second (as is supplied by your mains wall socket) then that shock can be serious. The power supply described here is very easy to understand and to make **BUT** if you get a shock from it that shock is very likely to kill you !!

Disclaimer: You are responsible for your own actions. This document is for information purposes only and if you decide to make or experiment with voltages higher than 12 volts, then you and you alone are responsible for your actions and neither the author, the web hosting service nor anyone else is responsible for what you do or for any damage or injury caused by your own actions.

Having said that, please understand that if you are careful and sensible, there is no danger in constructing this power generator in spite of the very high 400 volt input to this power driver circuit. To stay safe, you make all the necessary connections and **insulate** them **before** you apply power.

So, we need to construct an electronics component board to connect the Arduino to the phases of the motor. Please remember that this board will be carrying 400 volts and so you need to enclose the board in a plastic box **before** powering it up.

The suggestion for a physical layout for the components is based on using stripboard like this:

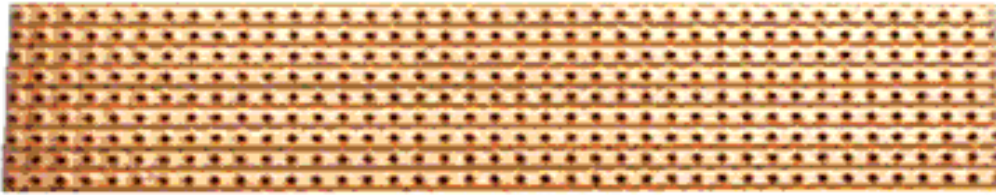

These boards come in many sizes and are very versatile. However, because the pin spacing of integrated circuit is just 0.1 inches, the solder joints can be very close together and that does not suit a beginner to soldering, so ask a friend for help in soldering unless you are already expert.

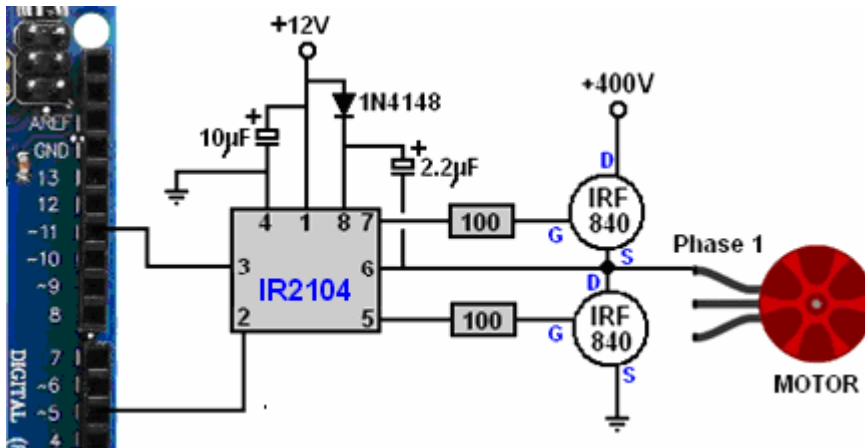

We want to place these components on the board, so perhaps a layout like this might be suitable:

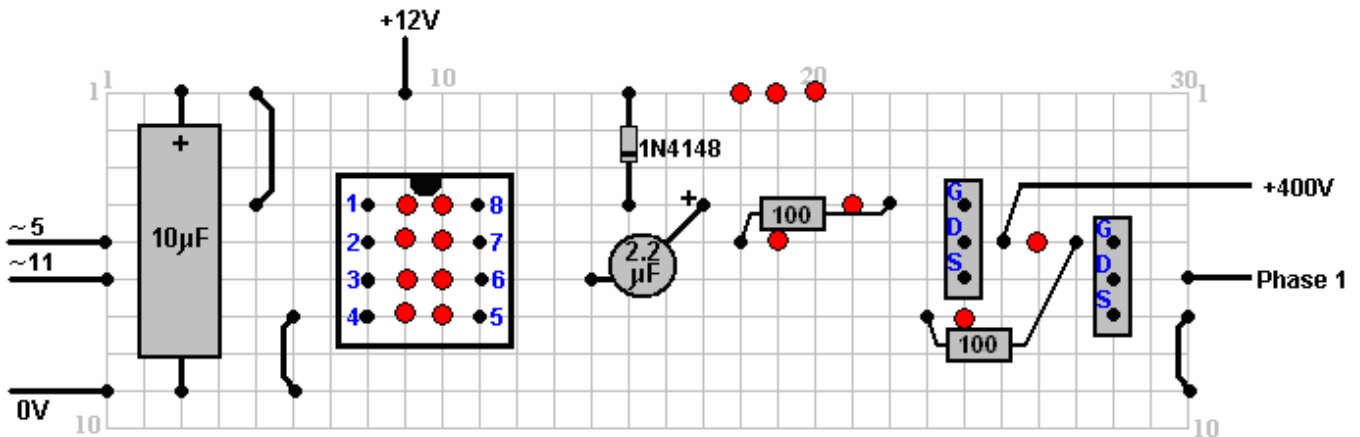

The red circles show where the copper strip on the underside of the board is to be broken. You can make three separate board, one for each phase or you can place all three circuits on a single board. Integrated circuits are heat sensitive so I suggest that you use a socket and solder it in place and then plug the chip into the socket when everything is cool. An 8-pin socket looks like this:



Here is a possible physical layout for the Arduino / Motor interface using a piece of stripboard with 29 copper strips each with 39 holes in it:

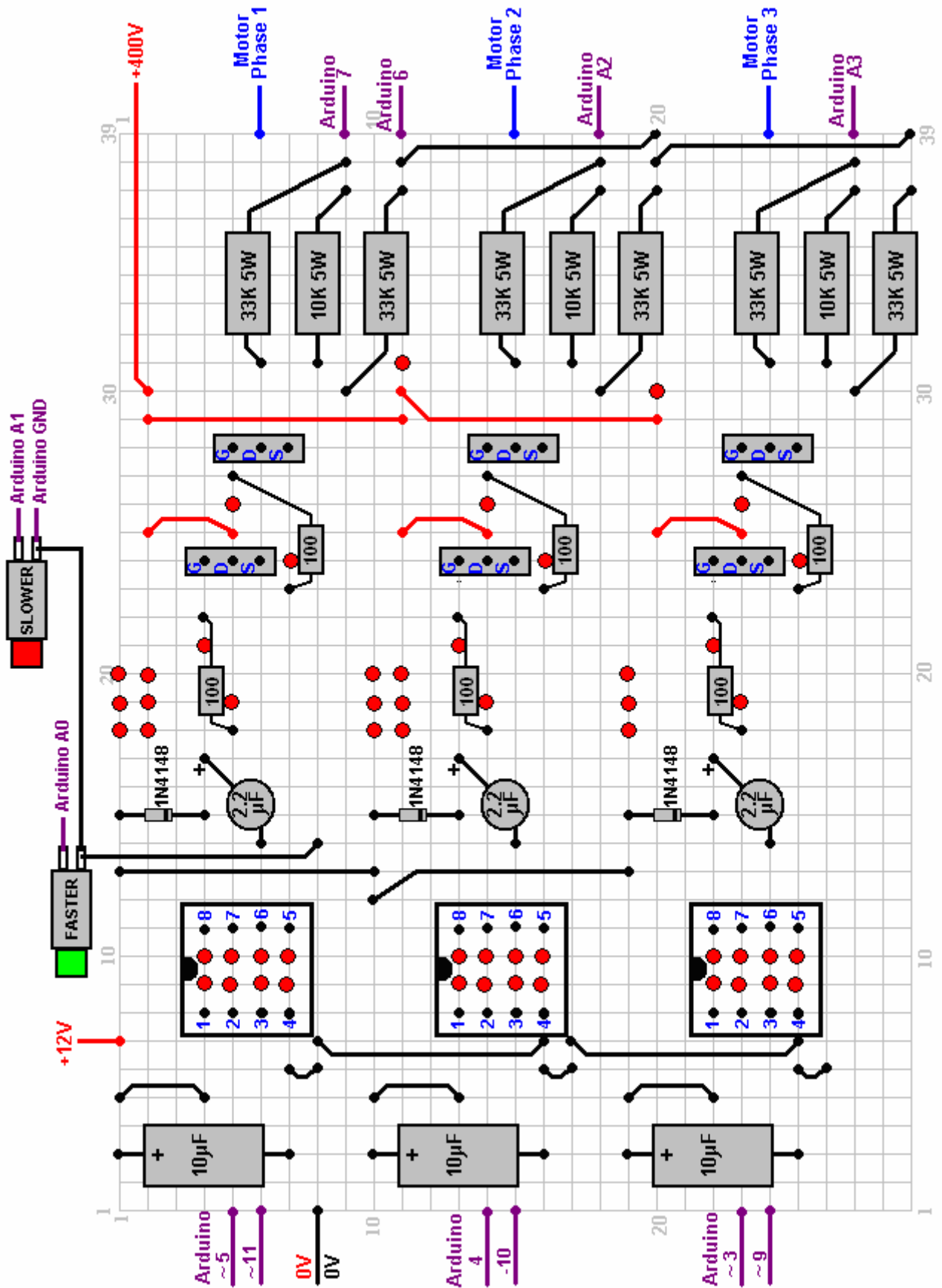

Thomas Buie describes the power supply method which he has used successfully in the past. It is a very simple arrangement which uses readily available parts which can be purchased easily through the internet:

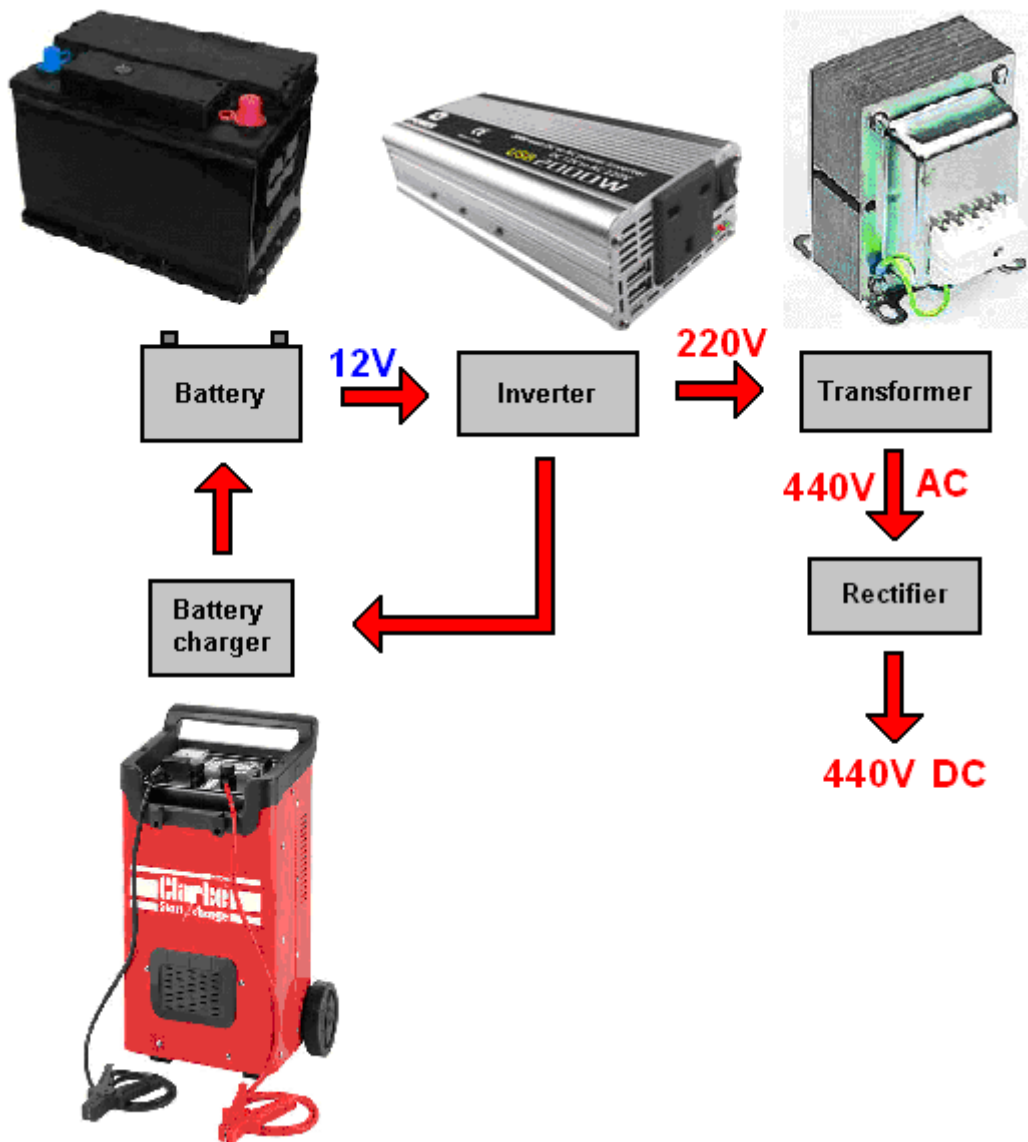

First, there is a car battery and that feeds an inverter like this particular unit which is an European inverter which produces anything from 220 to 240 volts with powers of 2000 watts continuous and 4000 watts peak output. It is also cheap at £25 delivered and it has two handy USB output power sockets as well:



However, we want 400 volts or more at 1 amp or more, and as that is some 800 watts for a 12 volt inverter like this, so Thomas has used a transformer to step the voltage up higher:



Getting a transformer like this is not at all easy as very few people want a 400 volt power supply. However, if you use one of the common 115V to 220V transformers of sufficient power rating, then the voltage is lifted high enough if you connect the transformer in reverse. One supplier is <https://www.testers.co.uk/defender-3-3kva-step-up-transformer-2-x-16a-outlets-240v>.

The rectification is very straightforward:

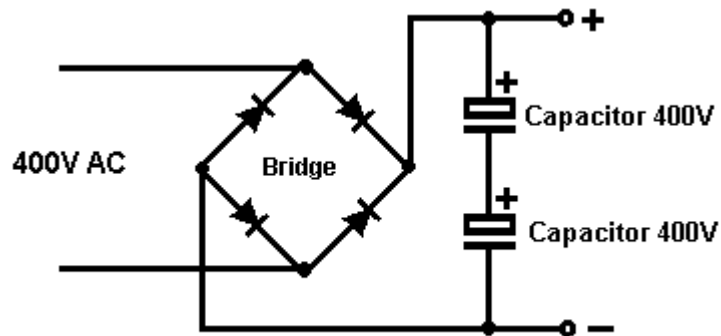

A possibility which bypasses the need for a transformer of that type would be to use a voltage doubler circuit to raise the inverter output up to 440 volts or so, the diodes being say, 1N5408 or UF5408 which can handle 1000 volts at 3 amps which is a good deal more than is needed for this system:

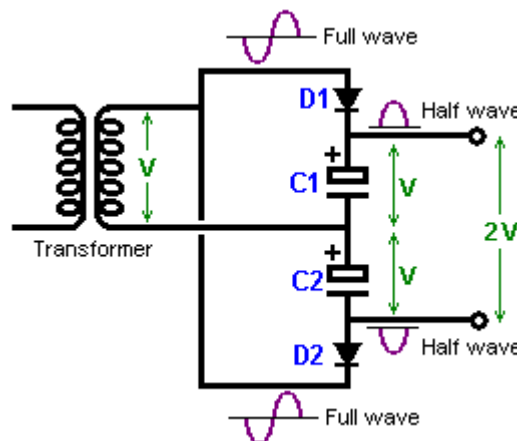

The disadvantage of doing that is that the output is effectively only a half-wave power supply. The capacitors would be 400 volts each and so the output capacitance would be safe for anything up to 800 volts. The transformer in the diagram is inside the inverter and "V" in the diagram would be 220 volts, giving an output of 440 volts.

One possibility which avoids the need for a transformer and still provides a full wave rectified 440V output is to use two 220V inverters:

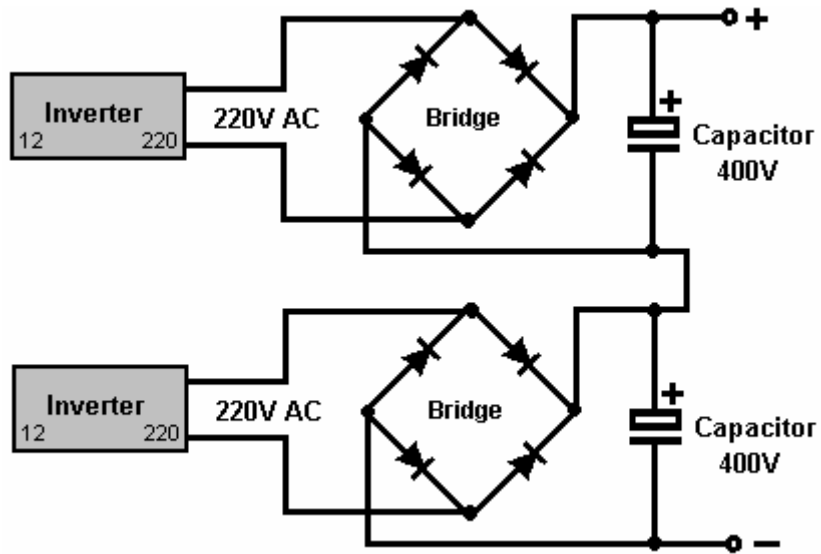

In this arrangement, both inverters are supplied by a single car battery and the output is 440 volts. Each inverter supplies only half of the wattage.

It is suggested that a method which skips both the inverter and the transformer would be to use a "DC chopper" circuit which could take the 12 volts from the car battery and produce a 400 volt 20 kHz output directly in one operation. A DC chopper of that type looks like this:

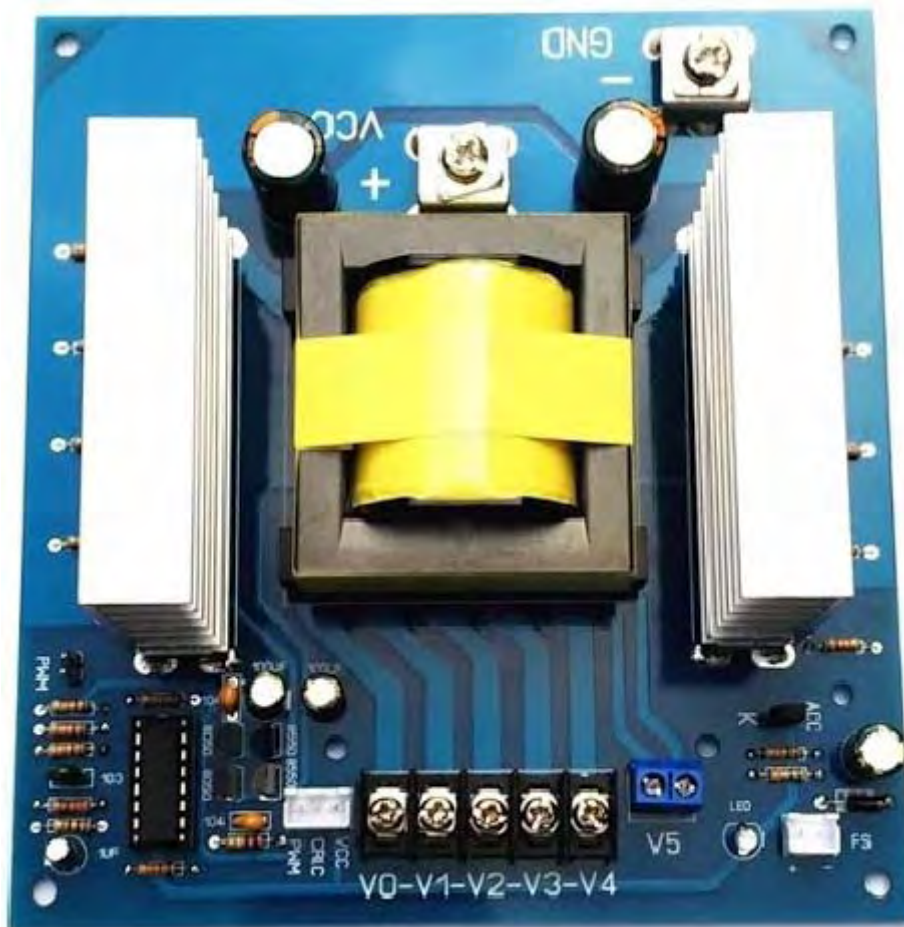

While a DC chopper power supply is not suitable for all applications, it is felt that this cheap unit costing US \$35 from <https://s.click.aliexpress.com/e/1rHgPQC> would be suitable for this generator project.

While the circuit wiring is shown above, we need a physical board with the electronic components attached to it. The wiring connections are normally soldered joints but making those joints can be quite difficult as some of them are very close together. If you are experienced at soldering, then there should be no problem, but if you have not soldered before, then you should get an experienced friend to do the soldering for you. Here is a suggested board layout using stripboard often called "Veroboard".

No matter how the 400 volts is generated, it is necessary to feed some 70 amps back to the battery output and inverter input to sustain the motor indefinitely. While the diagram above just shows a battery charger, the level of feedback is much higher than any ordinary battery charger can supply. So, we are talking about a professional-level charger able to deliver some 700 watts of power continuously. This generator system has a Coefficient Of Performance greater than 14 but even with that high performance it needs an input of about 700 watts for an output of 10,000 watts. Consequently, this "battery charger" link is very important and commercial units which can do the job cost something like £150.

We come now to the alternator which produces the electrical output which is the whole point of the system. All of the components and methods described so far have the objective of spinning the alternator indefinitely in order to provide electrical power for a household. However, please understand clearly that your local power company is most unlikely to allow you to connect your generator up to their wiring which goes to your fuse box. Consequently, it is better if you use your new supply of electrical power as if it were an emergency back-up generator. That is, you connect it up to your appliances without connecting it to any external power supply or wall socket.

The system described so far is perfectly capable of driving an alternator of any power level up to ten kilowatts without altering any of the components. So, the size of the alternator which you buy is up to you. Personally, I would consider an output of five kilowatts as being adequate to excessive, but then my electrical needs are probably far lower than yours might be.

Anyway, in the UK one supplier is MachineMart and they offer three different alternators. They look like this and each needs to be driven at 3000 rpm:



MachineMart 6.5 KVA
alternator £324
Pulley £15

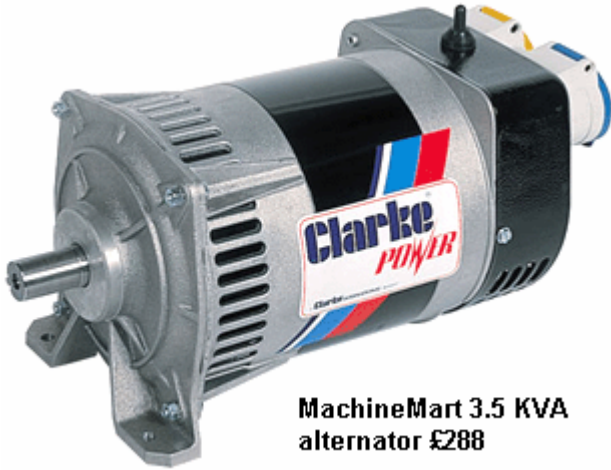

**MachineMart 3.5 KVA
alternator £288**

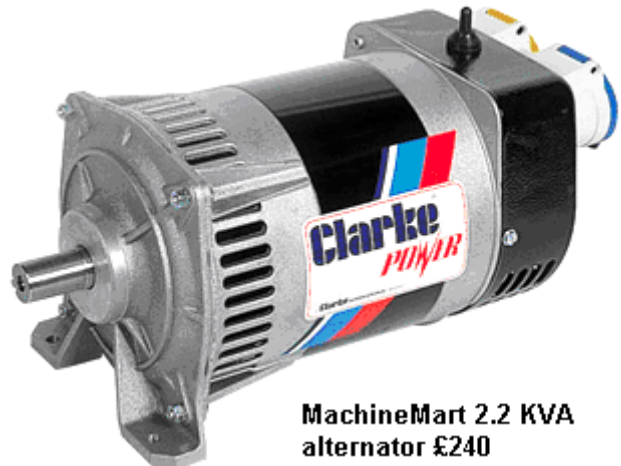

**MachineMart 2.2 KVA
alternator £240**



**118mm V-Belt Pulley
24/8mm £15**

Looking at the small price difference between the alternators, there seems to be very little reason not to pick the 6.5 KVA unit even if your expected current is likely to be well below that rating.

The final step is to mount the motor unit and alternator unit together so that the motor can drive the alternator to provide the required electrical output:

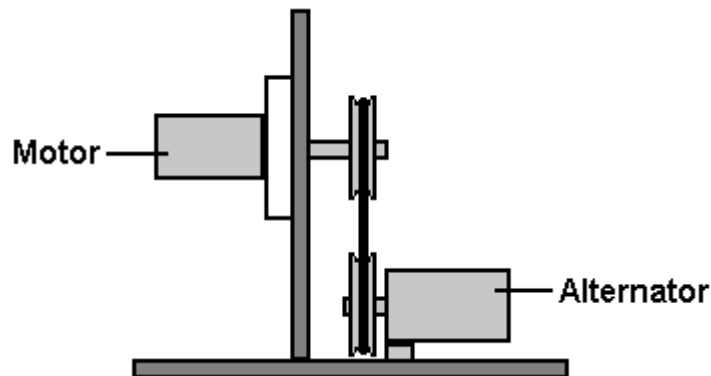

Thanks is due to Thomas Buie for sharing his design freely. Thomas has joined with the Free Energy Special Interest Group (“FESIG”) and they are preparing a series of instruction videos and actual physical construction of an a generator via the website <http://www.truevisionofpeace.com/fesig.html> and you can ask questions during the live sessions. Thomas’ own website is <https://www.youtube.com/channel/UCDiOZIHfkioVtHfSzS2qPWg>.

The Arduino code file www.free-energy-info.com/Arduino.txt is a free download and this document is available free from www.free-energy-info.com/BuieMorin.pdf.

There is one issue which needs to be dealt with and that is the plastic construction of parts of the motor. The motor was intended to power a washing machine and because that operation is slow and the mechanical stresses involved are fairly low, plastic was used. In this application the stresses are much higher and the usage is all day every day as opposed to the occasional use of a washing machine (my

apologies to mothers with children), it would be necessary to replace the plastic parts with mild steel, both for the hub of the rotor and the casing of the stator in order to drive the larger sizes of alternator. Machining by a local steel fabrication shop may be necessary unless you already own a lathe or have access to one. Alternatively, Gerard Morin offers those components although at what looks to me like rather large prices at <https://www.hyper-drive-hv.com/> the idea being that the existing plastic rotor boss:



is replaced with a metal unit:



and the motor effectively rebuilt until only the original coils and magnets remain:



While doing that adds considerable extra cost and effort, it does result in a very robust and powerful motor which is ready to drive a large alternator.

Let me stress that if you were to construct a generator system like this, you do not connect it to the wiring of the local electricity power supply company. For example, the electrical mains supply wiring will come into your household fuse box or contact breaker box. Do not connect your generator wiring to that same box but instead treat your generator in the same way as an emergency generator, feeding the generator output directly to your washing machine, electric heater, vacuum cleaner or whatever through an extension cable and not through a wall socket.

If you are very keen to have your new generator connected to your fuse box, then be sure to install a "Break-before Make" heavy duty switch to disconnect the outside power supply cable before your generator output is connected to the fuse box. This is important because if a fault occurs in the mains wiring and they turn off the mains power while they fix it, the workmen might get a fatal shock from your generator even though their wiring is supposed to be switched off.

Update 17th March 2019

It has been pointed out that this possible version of the interface board which goes between the Arduino and the 400-volt drive to the 3-phase motor has one feature which could be considered to be a potential weakness. The three red arrows show a copper strip which passes from the 12-volt Arduino area into the 400-volt motor area and it is felt that there is the potential for a back-EMF voltage spike to be fed back along that copper track and damage the IR2104 chip or even the Arduino board itself. It is suggested that the introduction of a fast Schottky diode in those links would block that possibility. For that we would need a Schottky diode which can withstand the 400 to 500 volts which gets fed to the motor and the current needed by the motor.

The Mouser supplier of electronic components has a range of such diodes. For example:

- SCS306AHGC9 rated at 650 volts, 6 amps and 46 watts, sells for £2.91
- SCS308AHGC9 rated at 650 volts, 8 amps and 57 watts, sells for £3.47
- SCS310AHGC9 rated at 650 volts, 10 amps and 71 watts, sells for £4.04
- SCS312AHGC9 rated at 650 volts, 12 amps and 78 watts, sells for £4.76
- SCS315AHGC9 rated at 650 volts, 15 amps and 93 watts, sells for £5.08
- SCS320AHGC9 rated at 650 volts, 20 amps and 115 watts, sells for £6.17

The packaging is like this:

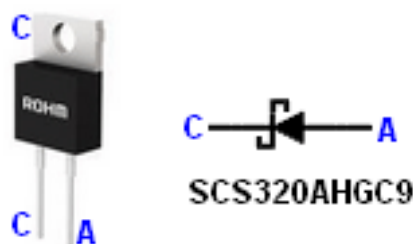

So, if we are to take the advice which recommends one of these diodes placed in line with lines which lead out to each phase of the motor, then the board layout would change to this:

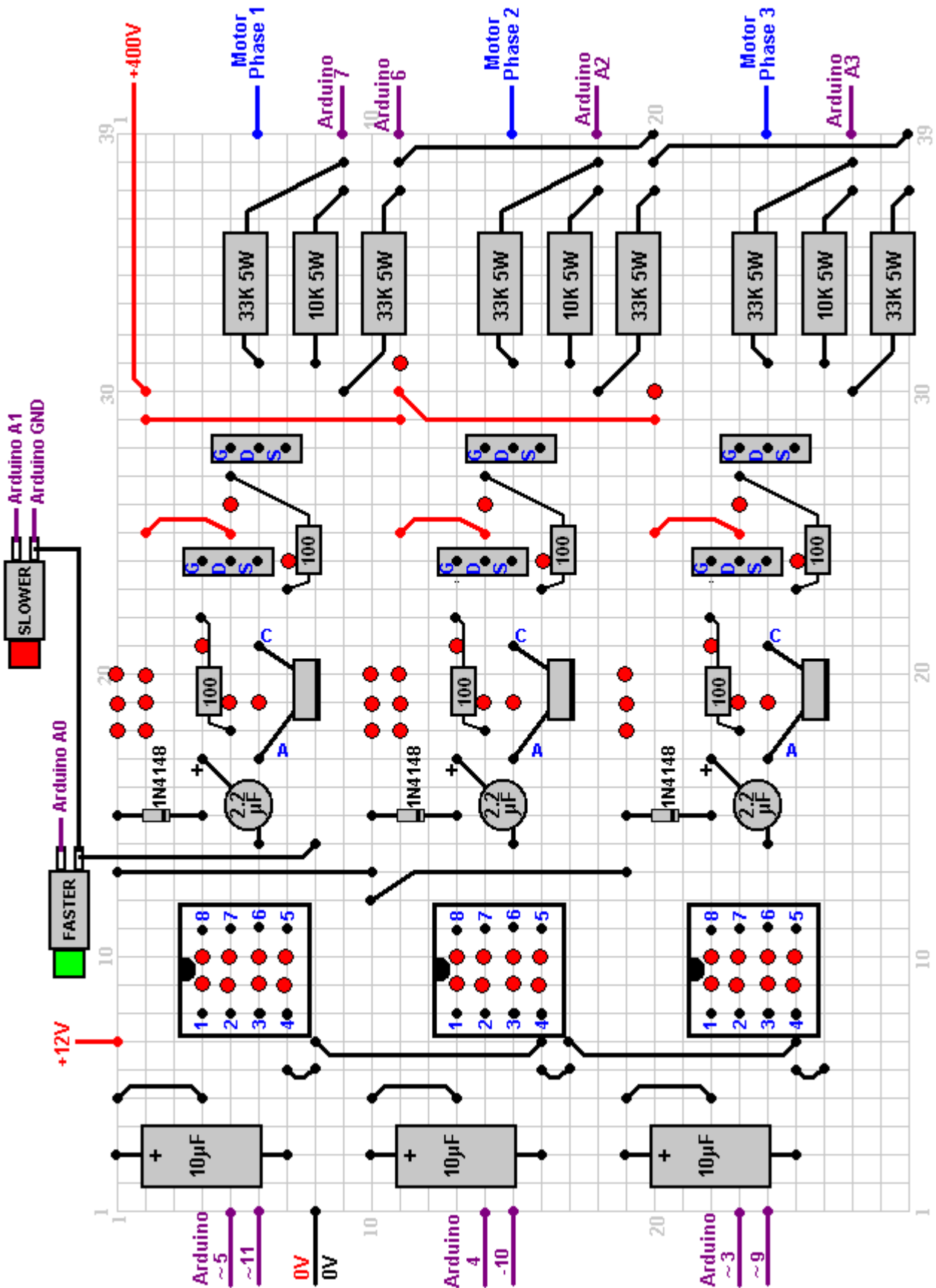

However, please understand that the FESIG presentation deals with the construction of a multi-kilowatt generator in far greater detail than this and that includes the construction of a much more robust interface between the Arduino and the 3-phase motor. That interface does not use the IR2104 chip but instead constructs the interface using discrete components which are believed to be much more robust than the IR2104 chip. The FESIG presentation is to cover the operation and other relevant details of

each component used in the construction and so the people being trained should understand clearly how every part of the generator works and so be able to perform maintenance if that should ever prove to be necessary.

Patrick Kelly

www.free-energy-info.com